

FURUNO

INSTALLATION MANUAL

MARINE RADAR

MODEL FR - 1410DS/1430DS



FURUNO ELECTRIC CO., LTD.
NISHINOMIYA, JAPAN

©FURUNO ELECTRIC CO., LTD.

9-52, Ashihara-cho,
Nishinomiya, Japan 662

Telephone: 0798-65-2111
Telefax: 0798-65-4200

All rights reserved. Printed in Japan

-Your Local Agent/Dealer

FIRST EDITION : MAY 1992
B : MAY 13, 1997

(HIMA) PUB. No. IME-33690-B
FR-1410DS/1430DS





SAFETY INSTRUCTIONS

DANGER



Do not work inside the equipment unless totally familiar with electrical circuits.

Hazardous voltage which will cause death or serious injury exists inside the equipment.

WARNING



Wear a safety belt and hard hat when working on the antenna unit.

Serious injury or death can result if someone falls from the radar antenna mast.



Turn off the power at the mains switchboard before beginning the installation. Post a sign near the switch to indicate it should not be turned on while the equipment is being installed.

Fire, electrical shock or serious injury can result if the power is left on or is applied while the equipment is being installed.

WARNING

Radio Frequency Radiation Hazard

The radar antenna emits electromagnetic radio frequency (RF) energy which can be harmful, particularly to your eyes. Never look directly into the antenna aperture from a close distance while the radar is in operation or expose yourself to the transmitting antenna at a close distance.

CAUTION



Ground the equipment to prevent electrical shock and mutual interference.

Confirm that the power supply voltage is compatible with the voltage rating of the equipment.

Connection to the wrong power supply can cause fire or equipment damage. The voltage rating appears on the label at the rear of the display unit.

Use the correct fuse.

Use of a wrong fuse can cause fire or equipment damage.

WARNING



Turn off the radar power switch before servicing the antenna unit. Post a warning sign near the switch indicating it should not be turned on while the antenna unit is being serviced.

Prevent the potential risk of being struck by the rotating antenna and exposure to RF radiation hazard.

Table of Contents

SYSTEM CONFIGURATION	0-1
EQUIPMENT LIST.....	0-2
ACCESSORIES LIST	0-3
INSTALLATION MATERIALS LIST	0-4
SPARE PARTS LIST	0-8
CHAPTER 1 INSTALLATION.....	1-1 to 1-9
1.1 GENERAL	1-1
1.2 SITING CONSIDERATIONS.....	1-1
Magnet Compass Safe Distance.....	1-1
Maximum Length of Cables.....	1-1
Scanner Unit Siting	1-1
Display Unit Siting.....	1-3
1.3 SCANNER UNIT INSTALLATION.....	1-4
Scanner Unit Assembling	1-4
How to Mount Scanner Unit.....	1-7
1.4 DISPLAY UNIT INSTALLATION	1-9
Fixing Procedure (for tabletop mounting)	1-9
Change for Bulkhead Mount.....	1-9
CHAPTER 2 INTERCONNECTION	2-1 to 2-6
2.1 GENERAL	2-1
2.2 CONNECTIONS TO DISPLAY UNIT.....	2-1
Fabricating the Power Cable.....	2-1
Fabricated Multicore Cable	2-1
Fabricating Non-terminated Multicore Cable (RW-6895)	2-2
Connections	2-3
2.3 CONNECTIONS TO SCANNER UNIT	2-4
Signal Cable RW-6895	2-4
De-icer Cable DPYCY-3.5 (Option)	2-5
2.4 RECTIFIER UNIT INSTALLATION AND CONNECTION (OPTION).....	2-6
CHAPTER 3 POST INSTALLATION ADJUSTMENT	3-1 to 3-18
3.1 OPERATION CHECK.....	3-1
3.2 ADJUSTMENT PROCEDURE	3-2
Adjustment by menu.....	3-2
3.3 MAGNETRON HEATER VOLTAGE ADJUSTMENT.....	3-4
3.4 TRANSMISSION TIMING ADJUSTMENT	3-6
3.5 HEADING MARK ALIGNMENT	3-7
3.6 TUNING ADJUSTMENT	3-9
3.7 MBS (MAIN BANG SUPPRESSION) ADJUSTMENT	3-9
3.8 VIDEO LEVEL AND VIDEO STC ... ANTENNA HEIGHT INPUT	3-10
3.9 INITIAL SETTING MENU	3-10
procedure.....	3-12
PULSE WD (Transmission Pulsewidth).....	3-12
ON TIME/TX TIME.....	3-12

ECHO AVG W/O GYRO	3-12
KEY BEEP (Key Response Tone).....	3-12
LOG PLS (Log Pulse).....	3-12
VID SIG (Video Signal).....	3-13
ALM LVL (Guard Alarm Signal Level).....	3-13
INT REJ (Interference Rejection).....	3-13
DISPLAY (Display Selection).....	3-13
DEFAULT SETTINGS.....	3-13
TRAIL W/ HLDG RNG (Restart of trailing when the range is changed)	3-13
CURSOR GYRO DISP (Gyro-linked Bearing Scale).....	3-13
ES ON SHRT RNG (Enlargement of Short Range Echo).....	3-13
3.10 SETTING FOR CURSOR GYRO MODE.....	3-17
3.11 SELF TEST.....	3-17

APPENDIX A SETTING OF GYRO CONVERTER GC-7..... A-1 to A-11

INTERCONNECTION DIAGRAM.....S-1

DISPLAY UNIT GENERAL SCHEMATIC DIAGRAM.....S-2

OUTLINE DRAWINGS D-1 to D-6

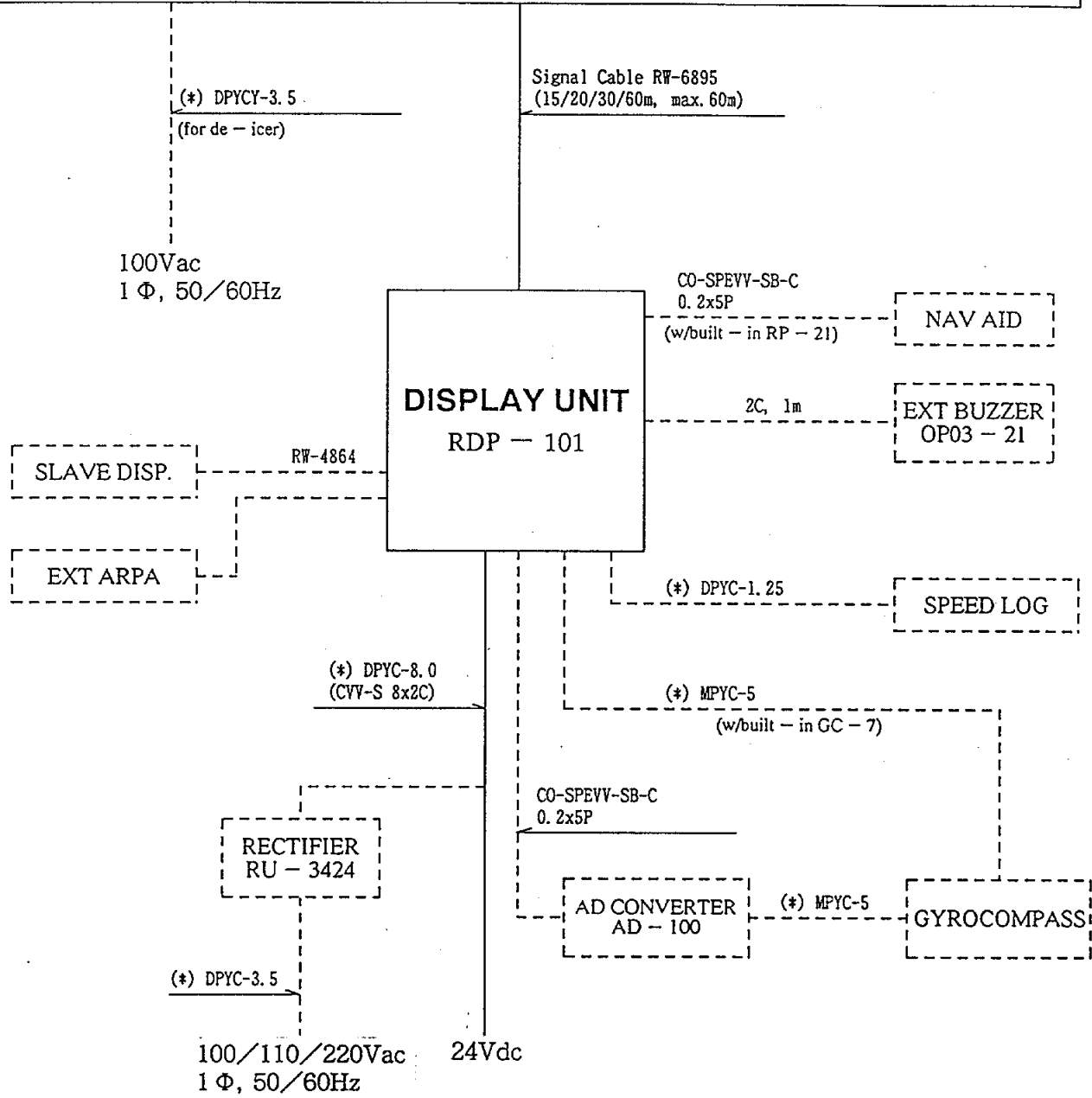
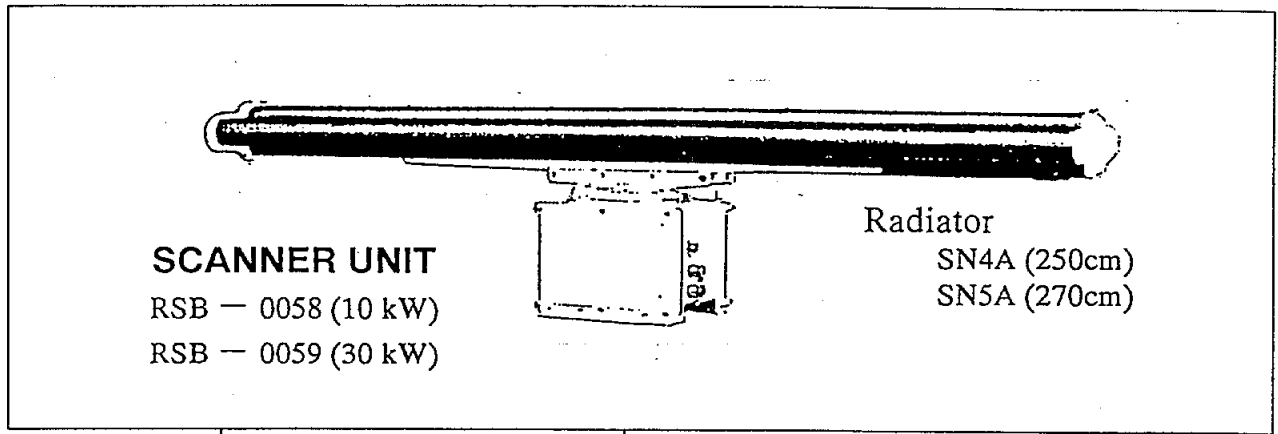





NOTE 1. * ... Prepare locally
2. Broken line ... Options

Complete Set

No.	Name	Type	Qty	Wt. (kg)	Remarks	
1	Scanner Unit	FR-1410DS (10kW)	SN4A-RSB-0058-N	1	77	250 cm radiator, standard
			SN4A-RSB-0058-I		77	250 cm radiator, w/de-icer
			SN5A-RSB-0058-N		79	270 cm radiator, standard
			SN5A-RSB-0058-I		79	270 cm radiator, w/de-icer
		FR-1430DS (30kW)	SN4A-RSB-0059-N	1	79	250 cm radiator, standard
			SN4A-RSB-0059-I		79	250 cm radiator, w/de-icer
			SN5A-RSB-0059-N		81	270 cm radiator, standard
			SN5A-RSB-0059-I		81	270 cm radiator, w/de-icer
2	Display Unit	RDP-101	1	33		
3	Accessories		1 set			
4	Installation Materials		1 set			
5	Spare Parts		1 set			
6	Gyro Converter	GC-7	1 set		option, built in display unit	
7	Cursor Gyro	CG-1400	1 set			
8	Video Plotter	RP-21	1 set			
9	Auto Plotter	ARP-21	1 set			
10	Non Glare Filter	OP03-68	1 set		option	
11	External Buzzer	OP03-21	1 set			
12	Handgrip	OP03-70	1 set			
13	Power Cable	CVV-S 8x2C	15m			
14	Performance Monitor	PM-50	1 set			
15	Rectifier Unit	RU-3424	1 set	25	option, for 100/110/220Vac mains	
16	Rectifier Unit	RU-1746B-2	1 set	17	option, for 100/110/220Vac mains (for 10kW, SN4A type only)	
17	Transformer Unit	RU-3305	1 set	12.2	option, for 110/220Vac mains, for de-icer	
18	Signal Cable (non-terminated)	RW-6895			option, specify length	
	Termination Materials	OP03-75	1 set		option, code no. 008-429-850	

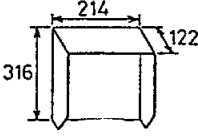
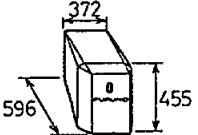
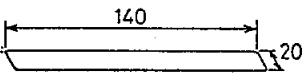
FURUNO

CODE No.	000-084-760	03DX-X-9501-3
TYPE	FP03-04400	

付属品表 ACCESSORIES		FR-1410/1425 レーダー FCR-1401/1411/1421 MARK-3 FR-1410DS/1430DS/1460DS RADAR			
番号 No.	名称 NAME	略図 OUTLINE	型名/規格 DESCRIPTIONS	数量 Q'TY	用途/備考 REMARKS
1	フード組立品 HOOD ASSY.		FP03-04401	1	
			CODE No. 008-415-810		
2	ダストカバー DUST COVER		03-106-0201-0	1	
			CODE No. 100-148-830		
3	SWシート (E1) KEY LABEL		03-106-0221-1	1	機能キーステッカー (英文) FOR USER KEY (ENGLISH)
			CODE No. 100-148-901		
			CODE No.		
			CODE No.		
			CODE No.		
			CODE No.		
			CODE No.		
			CODE No.		
			CODE No.		
英文仕様 ENGLISH VERSION			図番 DWG. No. C3352-F01-D	1/1	
			検図 CHECKED		
					

FURUNO

CODE NO	008-429-880	03EB-X-9401-1
TYPE	CP03-12301	

工事材料表 INSTALLATION MATERIALS		FR-1410DS FR-1430DS	船舶用レーダー MARINE RADAR		
番号 No	名称 NAME	略図 OUTLINE	型名 / 規格 DESCRIPTIONS	数量 Q'TY	用途 / 備考 REMARKS
1	圧着端子 CRIMP-ON LUG		FVD1.25-3 赤 RED	2	
			CODE NO		
2	圧着端子 CRIMP-ON LUG		FV1.25-M3 赤 RED	26	
			CODE NO		
3	圧着端子 CRIMP-ON LUG		FV5.5-4 黄 YEL	6	
			CODE NO		
4	アース線 COPPER STRAP		RW-4747	1	
			CODE NO		
5	六角ボルト HEX. BOLT		M6X25 SUS304	1	
			CODE NO		
6	六角ナット 1種 HEX. NUT		M6 SUS304	1	
			CODE NO		
7	ミカキ平座金 FLAT WASHER		M6 SUS304	3	
			CODE NO		
8	ハネ座金 SPRING WASHER		M6 SUS304	1	
			CODE NO		
9	六角ボルト(全ネジ) HEX. BOLT		M12X60 SUS304	4	
			CODE NO		
10	六角ナット 1種 HEX. NUT		M12 SUS304	4	
			CODE NO		
空中線部用 FOR SCANNER UNIT			図番 (1/2) DWG. NO. C3369-M01-B		
			検図 CHECKED		

FURUNO

CODE NO.	008-429-880	03EB-X-9402-1
TYPE	CP03-12301	



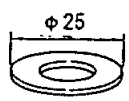
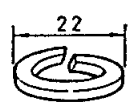
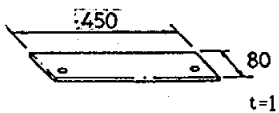
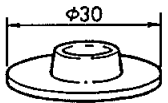



工事材料表 INSTALLATION MATERIALS	FR-1410DS FR-1430DS	船舶用レーダー MARINE RADAR
----------------------------------------	------------------------	-------------------------

番号 No.	名称 NAME	略図 OUTLINE	型名 / 規格 DESCRIPTIONS	数量 Q'TY	用途 / 備考 REMARKS
11	ミカキ平座金 FLAT WASHER		M12 SUS304	4	
			CODE NO. 000-864-132		
12	ハネ座金 SPRING WASHER		M12 SUS304	4	
			CODE NO. 000-864-263		
13	防蝕ゴム CORROSION-PROOF RUBBER MAT		03-029-0301-1	2	
			CODE NO. 100-091-111		
14	シールワッシャー SEAL WASHER		03-001-3002-0	4	
			CODE NO. 300-130-020		
			CODE NO.		
			CODE NO.		
			CODE NO.		
			CODE NO.		
			CODE NO.		
			CODE NO.		

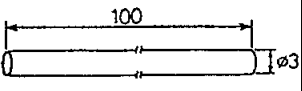
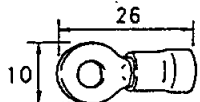
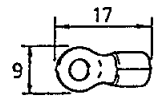
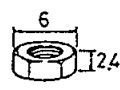
空中線部用 FOR SCANNER UNIT	図番 (2/2) DWG. NO. C3369-M02-B
検図 CHECKED	  

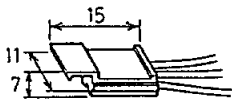
FURUNO



CODE NO	008-424-590	03DZ-X-9401-1
TYPE	CP03-11601	

工事材料表 INSTALLATION MATERIALS		FR-1410DS FR-1430DS FR-1460DS		船舶用レーダー MARINE RADAR	
番号 No	名称 NAME	略図 OUTLINE	型名 / 規格 DESCRIPTIONS	数量 Q'TY	用途 / 備考 REMARKS
1	スミチューブ HEAT-SHRINK TUBE		3X0.25 黒 BLACK *10CM* CODE NO 000-105-874	1	NHコネクタ組品 接続用 FOR NH CONNECTOR ASSY.
2	圧着端子 CRIMP-ON LUG		FV5.5-4 CODE NO 000-538-123	2	トランス、整流器 用 FOR TRANSFORMER & RECTIFIER
3	圧着端子 CRIMP-ON LUG		8NK4 CODE NO 000-538-180	4	DC電源接続用 FOR DC MAINS CONNECTION
4	六角ナット 1種 HEX. NUT		M3 C2700W MBNI2 CODE NO 000-863-204	2	28Pフック 固定用 FOR 28P CONNECTOR (DP1)
5	ミカキ平座金 FLAT WASHER		M3 C2600P MBNI2 CODE NO 000-864-104	2	28Pフック 固定用 FOR 28P CONNECTOR (DP1)
6	ハネ座金 SPRING WASHER		M3 C5191W MBNI2 CODE NO 000-864-204	2	28Pフック 固定用 FOR 28P CONNECTOR (DP1)
7	NHコネクタ組品 NH CONNECTOR ASSY.		03-1499(3P) CODE NO 008-419-060	1	スピードログ 接続用 FOR SPEED LOG CONNECTION
			CODE NO		
			CODE NO		
			CODE NO		
指示部用 FOR DISPLAY UNIT			図番 (1/1) DWG. NO. C3357-M01-B		
			検図 CHECKED		
					

FURUNO

CODE NO		03EB-X-9403
TYPE		

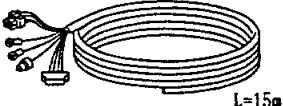
工事材料表 INSTALLATION MATERIALS		FR-1410DS FR-1430DS	船舶用レーダー MARINE RADAR	
----------------------------------------	--	------------------------	-------------------------	--

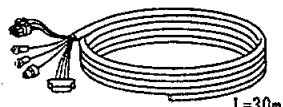
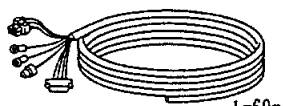
番号 No	名称 NAME	略図 OUTLINE	型名 / 規格 DESCRIPTIONS	数量 Q'TY	用途 / 備考 REMARKS
1	信号ケーブル SIGNAL CABLE	 L=15m	S03-47-15 (RW-6895 *15M*) CODE NO 008-432-650	1	
1	信号ケーブル SIGNAL CABLE	 L=20m	S03-47-20 (RW-6895 *20M*) CODE NO 008-432-660	1	
1	信号ケーブル SIGNAL CABLE	 L=30m	S03-47-30 (RW-6895 *30M*) CODE NO 008-432-670	1	
1	信号ケーブル SIGNAL CABLE	 L=60m	S03-47-60 (RW-6895 *60M*) CODE NO 008-432-680	1	
			CODE NO		
			CODE NO		
			CODE NO		
			CODE NO		
			CODE NO		
			CODE NO		

NO.1のいずれかを選択して下さい。
SELECT ONE.

図番 (1/1)
DWG. NO. C3369-M03-A

検図 CHECKED   

FURUNO

CODE No.	008-429-840	BOX No. _____ P _____
TYPE	SP03-09501	

SHIP No.	SPARE PARTS LIST FOR	U S E	SETS PER VESSEL
	FR-1410DS 船舶用レーダー FR-1430DS MARINE RADAR	指示部用 FOR DISPLAY UNIT	

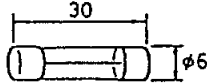
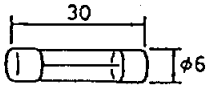
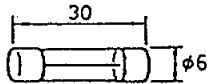
ITEM No.	NAME OF PART	O U T L I N E	DWG. No. OR TYPE No.	QUANTITY			REMARKS/CODE No.
				WORKING		SPARE	
				PER SET	PER VES.		
1	管入りヒューズ GLASS TUBE FUSE		FGBO 15A AC125V	1		2	
							000-549-014
2	管入りヒューズ GLASS TUBE FUSE		FGBO 0.5A AC125V	2		4	
							000-549-060
3	管入りヒューズ GLASS TUBE FUSE		FGBO 10A AC125V	1		2	
							000-549-065

MFR'S NAME	FURUNO ELECTRIC CO., LTD.	DWG. No.	C 3 3 6 9 - P 0 1 - B
------------	---------------------------	----------	-----------------------

FURUNO

CODE NO.	008-424-380	03DZ-X-9303-2
TYPE	SP03-09203	BOX NO. P

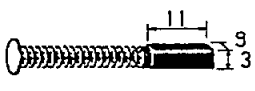
SHIP NO.	SPARE PARTS LIST FOR		U S E			SETS PER VESSEL
	FR-1410DS/1430DS/1460DS FR-2160DS L-2"- RADAR		空中線部用 FOR SCANNER UNIT			
ITEM NO.	NAME OF PART	O U T L I N E	DWG NO. OR TYPE NO.	QUANTITY		REMARKS/CODE NO.
				WORKING	SPARE	
				PER SET	PER VES.	
1	カーボンブラシ CARBON BRUSH		T-A01297B	4	4	000-115-023
MFR'S NAME	FURUNO ELECTRIC CO., LTD			DWG NO.	C3357-P03-D	1/1

CHAPTER 1 INSTALLATION

1.1 GENERAL

This radar system is mainly composed of two units, the display unit and the scanner unit. The RF transceiver is contained in the scanner unit for TR-UP configuration. The display unit and scanner motor are driven by 24 VDC mains. For 100/110/115 VAC mains, an external rectifier (RU-3424) is required. (Rectifier unit RU-1746B-2 may substitute for RU-3424 when FR-1410DS (10 kW type) is operated with 250cm antenna SN4A).

1.2 SITING CONSIDERATIONS

Magnet Compass Safe Distance

Unit	Standard Compass	Steering Compass
Scanner Unit RSB-0058 (10kW)	2.46m	1.85m
Scanner Unit RSB-0059 (30kW)	4.8m	3.6m
Display Unit RDP-101	1.2m	0.9m
Rectifier Unit RU-3424	1.8m	1.0m

Maximum Length of Cables

Cable	Max. Length
RW-6895 (Display unit-Scanner unit)	60m

Scanner Unit Siting

The scanner unit is generally installed on top of the wheelhouse or on the radar mast on an appropriate platform. When siting the unit, consideration must be given to the following points.

- 1) A funnel, mast or derrick post in line of sight of the radiator may cause blind sectors on the radar picture. A shadow sector between 355 and 5 degrees must be avoided by carefully planning the installation site.
- 2) Deposits and fumes from the funnel or other exhaust vent can adversely affect the aerial performance and hot gas tends to distort the radiator portion. The scanner unit must not be mounted in a place where it may be subjected to temperature in excess of 70°C.
- 3) The unit must not be positioned in close proximity to a direction finder aerial; separation of more than 2 meters is recommended.
- 4) Sufficient clearance should be allowed around the unit for checking and service.

INSTALLATION PRECAUTION FOR S-BAND SCANNER UNIT

If an S-band scanner unit is mounted near the end of a platform to provide sufficient rotation clearance for the radiator (see figure), the scanner unit, because of its weight, swings up and down by ship's vibration and rolling, exerting excessive levels of stress at the base of the radiator, which can damage the radiator. To prevent this, relocate the scanner unit, or if relocation is not possible reinforce the platform.

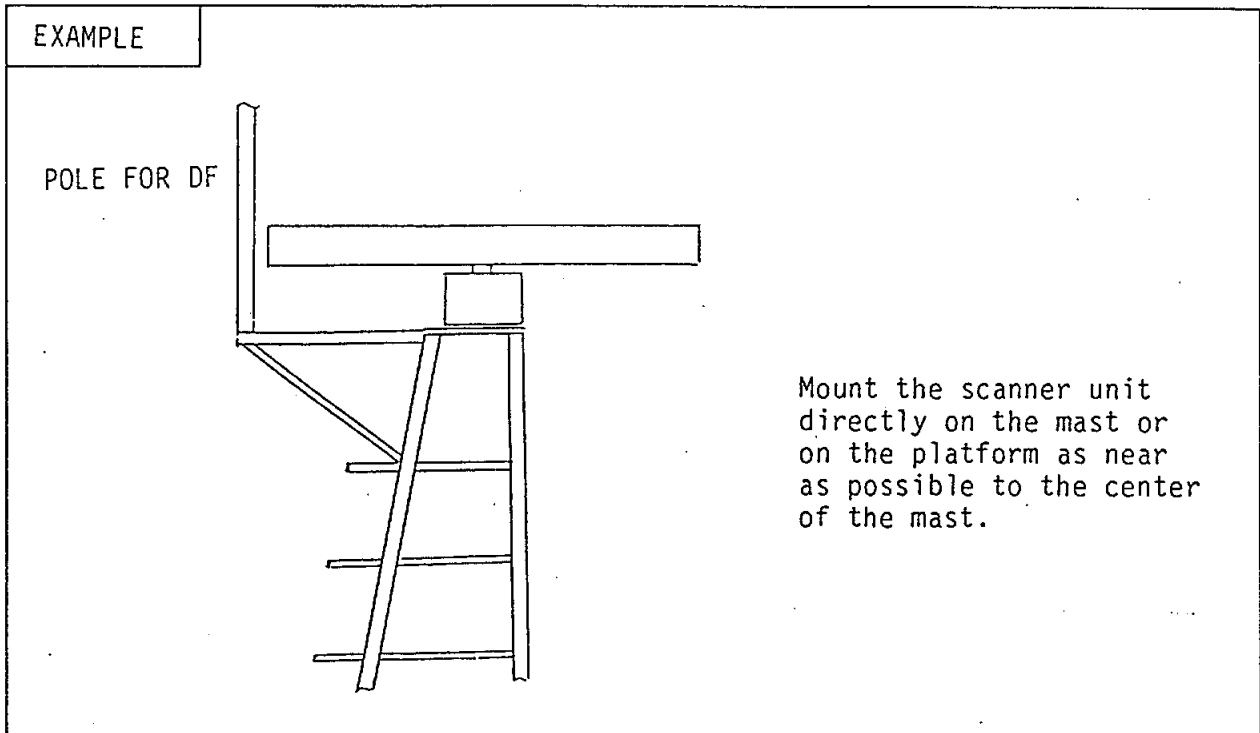
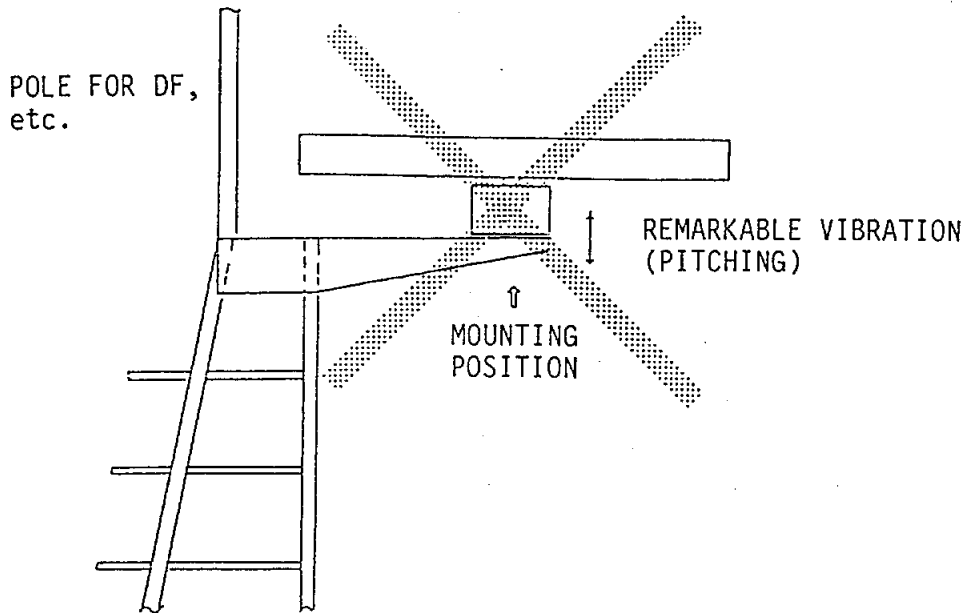

Display Unit Siting

Locate the display unit in a place where it can be viewed and operated conveniently but where there is no danger of salt or fresh water spray or immersion.

The orientation of the display unit should be so that the radar screen is viewed while the operator is facing the bow. This makes determination of position much easier.

The unit can be installed either on a tabletop or on a bulkhead. The mounting dimensions for this unit are shown in outline drawing on page D-1. You can use the mounting cradle itself as a template for marking the mounting bolt holes. Since the unit weighs 33 kg reinforce the mounting place, if necessary.

Make sure you allow enough clearance to get to the connectors behind the unit. Leave at least a foot or so of "service loop" of cables behind the unit so that it can be pulled forward for servicing or easy removal of the connectors. The recommended clearances for servicing ease are given in outline drawing.

1.3 SCANNER UNIT INSTALLATION

The antenna radiator and the scanner housing are shipped in separate packages and must be assembled at installation. Use the following procedure for mounting the scanner unit.

CAUTIONS:

- 1) Follow the safety rule and use safety devices for dangerous work on the radar mast.
- 2) The scanner base is made of aluminum cast. To prevent the scanner base from electrolytic corrosion, use the seal washers and corrosion-proof rubber mats and ground the unit with the grounding wire, supplied as the installation materials. Refer to page 1-8.
- 3) Be sure to apply the adhesive (Non-acid type silicone sealant) supplied as the installation materials to bolts, nuts and washers. Do not use other type of sealant which may contain acetic acid.
- 4) Do not paint the radiator aperture.
- 5) Do not lift the scanner unit by the radiator. (Use lifting hooks.)
- 6) When assembling the antenna radiator, apply the adhesive (coat of waterproof compound) between mating surfaces of rotary joint flange. Do not apply it to the O-ring and the groove for O-ring.

Scanner Unit Assembling

It is recommended to install the antenna radiator on the scanner base before mounting the scanner unit on the radar mast. Refer to the scanner unit assembling drawing on next page.

- 1) Remove two protection caps from the radiator flange and rotary joint flange.
- 2) Place the O-ring in the groove of the rotary joint flange. Make sure the O-ring is fully greased. Make very sure the O-ring is not pinched during assembling.
- 3) Secure the feeder waveguide on the rotary joint flange with four M6x16 hex bolts.
- 4) Fix the feeder waveguide on the radiator bracket with a waveguide clamp, a clamp insulator, two flat washer and two M6x50 hex bolts.
- 5) Place the greased O-ring in the groove of the radiator flange.
- 6) Put the antenna radiator on the bracket and fix it temporarily with eight M10x20 hex bolts, spring washers and flat washers.
- 7) Secure the feeder waveguide to the radiator flange with four M6x16 hex bolts.
- 8) Tighten the antenna radiator on the bracket with eight M10x20 bolts.

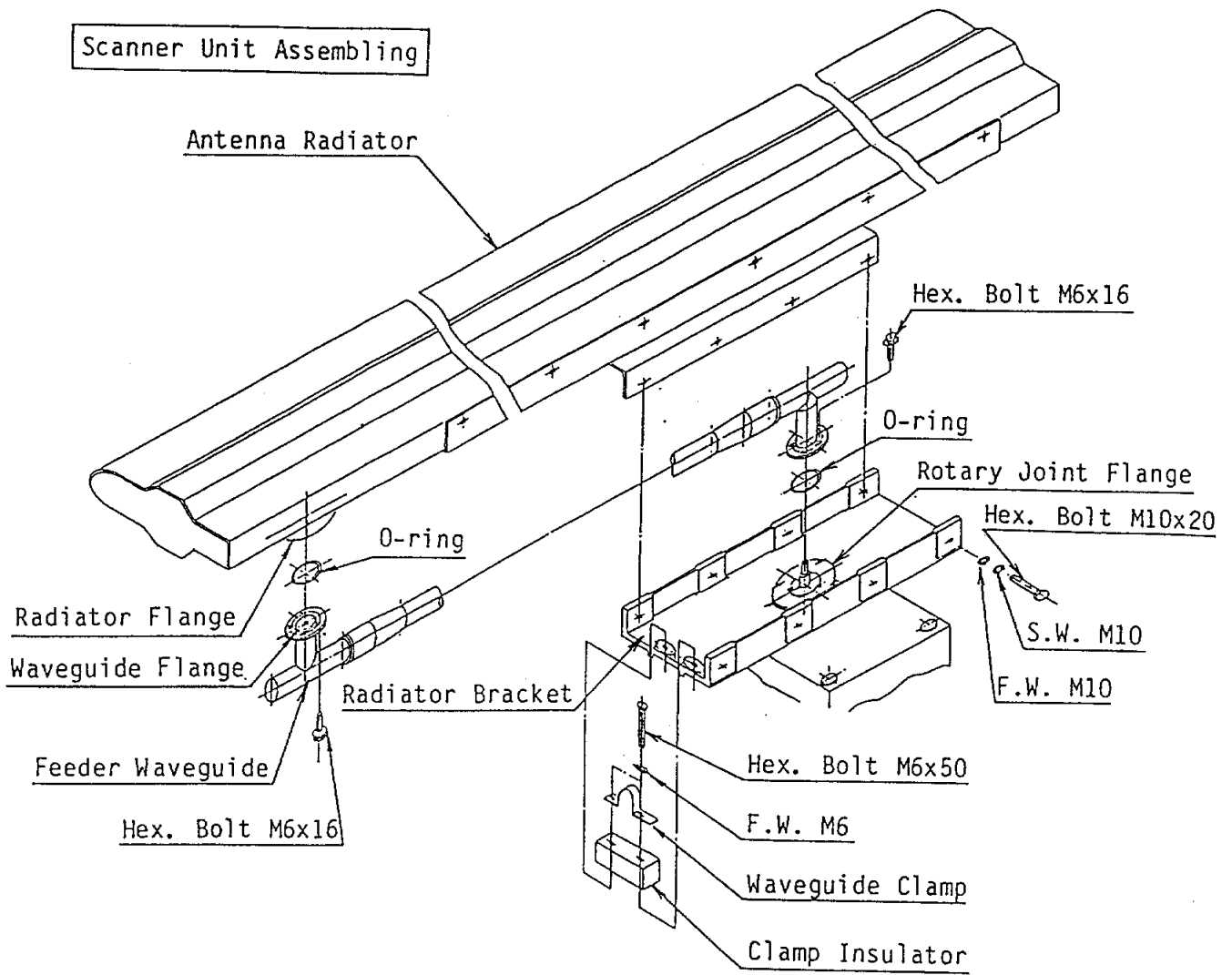

Note 1. Apply silicone sealant (supplied, non-acid type) on bolts, nuts, washers and waveguide flanges outside O-ring grooves to avoid electrolytic corrosion. (Do not apply sealant to O-ring and O-ring grooves.)

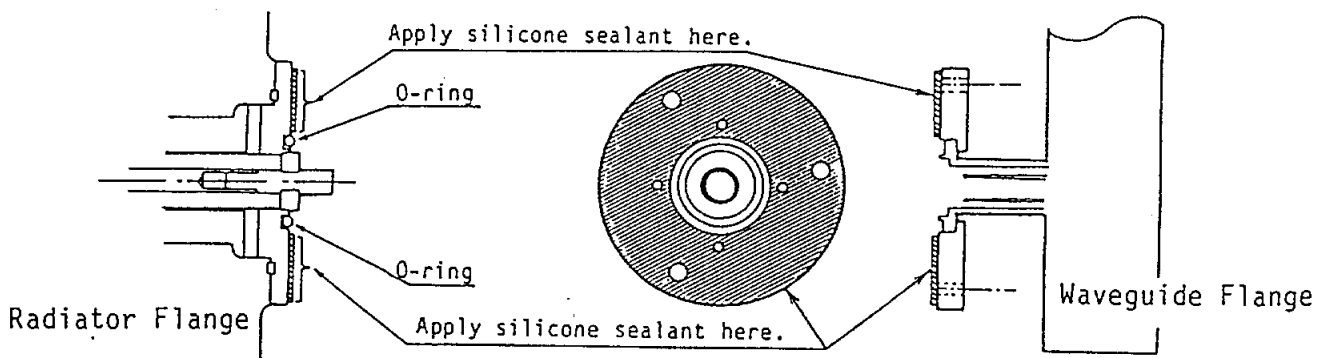



2. Do not pinch O-ring and keep it clean.

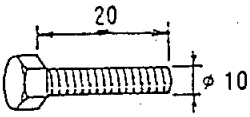
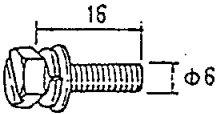

3. For packings of scanner covers and O-rings, do not use silicone sealant, but rather use grease.

FURUNO

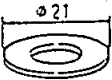
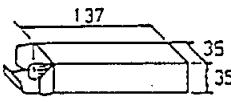
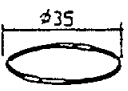
CODE No.	
TYPE	

工事材料表 INSTALLATION MATERIALS		レーダー空中線部組立材料 RADAR ANTENNA ASSEMBLING MATERIALS			
番号 No.	名称 NAME	略図 OUTLINE	型名 / 規格 DESCRIPTIONS	数量 Q'TY	用途 / 備考 REMARKS
1	六角ボルト HEX. BOLT		M10X20 SUS304 CODE No. 000-852-158	8	
2	六角セムスB(スリ割付) HEX. BOLT (SLOTTED, WASHER HEAD)		M6X16 SUS304 CODE No. 000-882-061	8	
3	バネ座金 SPRING WASHER		M10 SUS304 CODE No. 000-864-261	8	
4	ミガキ平座金 FLAT WASHER		M10 SUS304 CODE No. 000-864-131	8	
5	スパーズリーボンド ADHESIVE		1211 50g CODE No. 000-854-118	1	
6	O-RING		WP-20 1115-70 CODE No. 000-851-714	2	
			CODE No.		
			CODE No.		
			CODE No.		
			CODE No.		

FER SN4A/SN5A

図番 DWG. No. C3291-013-A	1/1
検図 CHECKED	  

How to Mount Scanner Unit

- 1) Drill four bolt holes (15mm dia.) in the radar mast platform or the deck, referring to the scanner outline drawing.
- 2) Place the corrosion-proof rubber mats supplied as the installation materials on the mounting platform where the scanner base will be positioned. This is to prevent the scanner base made of aluminum cast from the electrolytic corrosion.
- 3) Using two L-angled metal plates on the scanner top, lift the scanner base with the antenna radiator and place the scanner unit on the rubber mats so that the cable glands face the ship's stern.

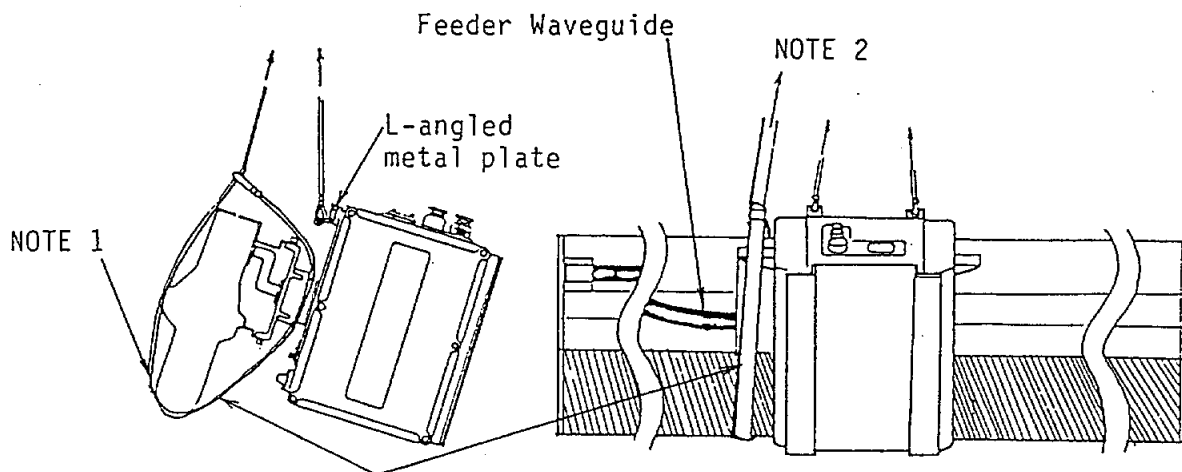

Put the rope around antenna radiator (feeder waveguide side) to prevent antenna from rotating when lifting up the antenna base.

- NOTE 1. Take care not to damage antenna surface by the rope.
2. Tensile load should not be applied to antenna radiator.

- 4) Fix the scanner base to the mounting platform by using four M12x60 hex bolts, nuts, washers and seal washers supplied as the installation materials.
- 5) Arrange the grounding terminal at the nearest grounding spot using an M6x25 hex bolt, nut and washers supplied as the installation materials. Then fix a grounding wire (RW-4747, 320mm long) to the terminal.
- 6) Connect the other end of the grounding wire to the grounding terminal of the scanner unit.
- 7) Apply silicone sealant supplied as the installation materials to the grounding terminal and the fixing bolts.

REMARKS ON INSTALLATION OF SCANNER UNIT

The scanner base is made of aluminum cast. To prevent the scanner base from electrolytic corrosion, place the seal washer and corrosion-proof rubber mat, and run the grounding wire between the grounding terminal fitted on the scanner body and the nearest grounding spot as illustrated below. (These parts are supplied as the installation materials.)

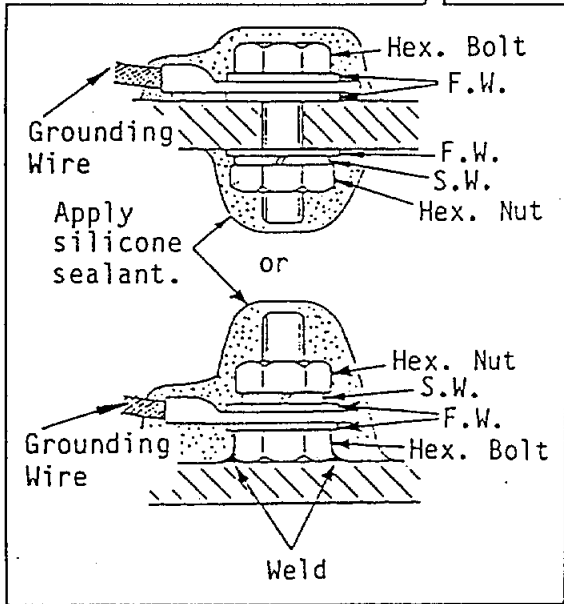
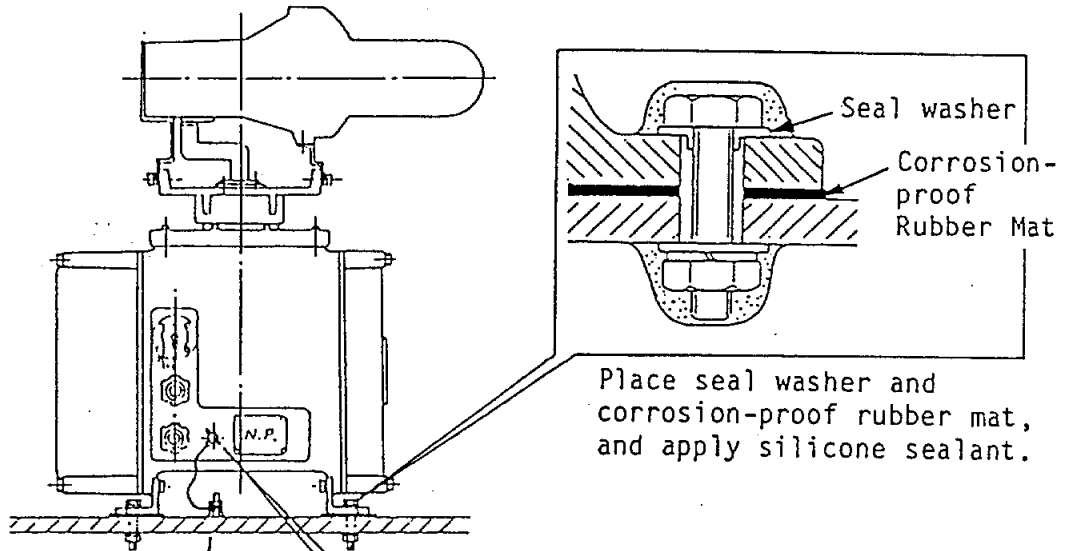

Arrange grounding terminal at the nearest grounding spot.

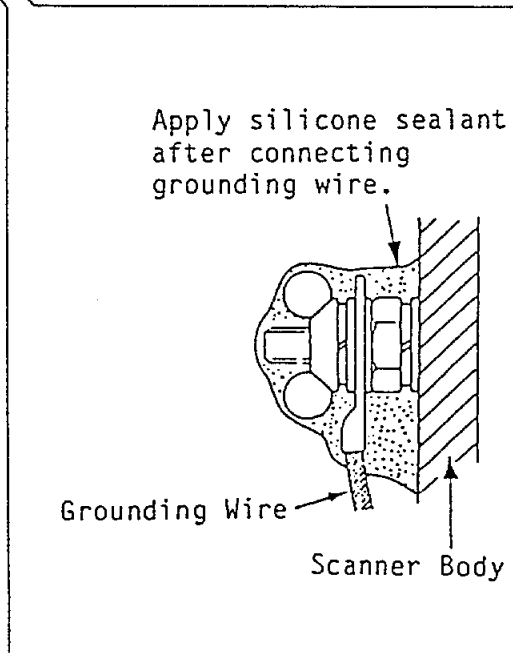

Grounding terminal is factory-fitted on the scanner body.

1.4 DISPLAY UNIT INSTALLATION

Refer to page 1-3 for deciding the mounting position of display unit.

Fixing Procedure (for tabletop mounting)

- 1) Separate the mounting base by unscrewing two hex. head bolts (M10).
- 2) Make four mounting holes (12mm dia.) on the mounting surface by using the mounting base as a template. (for fixing with bolts/nuts)
- 3) Fix the mounting base to the mounting surface by using four sets of M10 bolts/nuts or 9mm coach screws.
- 4) Fix the display unit on the mounting base.

Change for Bulkhead Mount

To fix the display unit on the bulkhead, replace the bottom plate to the top side of the display unit. After fixing the mounting base on the bulkhead, fit the display unit to the mounting base. Since the display unit weighs heavy (33 kg), reinforcement of bulkhead must be considered.

CHAPTER 2 INTERCONNECTION

2.1 GENERAL

Connections to display unit and scanner unit are described in paragraph 2.2 and 2.3 respectively. Refer to page S-1 "Interconnection Diagram" for connections between each unit.

2.2 CONNECTIONS TO DISPLAY UNIT

Two cables run to the display unit, the multicore cable (RW-6895) from the scanner unit and the power cable from the ship's mains or rectifier unit. The multicore cable is terminated with factory-wired connectors at the display side.

Fabricate the power cable (optional supply) as follows:

Fabricating the Power Cable

- 1) Remove the vinyl sheath by 200mm, taking care not to nick the braided shield.
- 2) Unwind the cloth tape and cut it off.
- 3) Expose about 40mm of the inner core of the braided shield.
- 4) Cut off the jute.
- 5) Remove the insulators of cores by about 10mm. Fix crimp-on lugs (8NK4, supplied) to the cores.
- 6) Wrap the braided shield with vinyl tape, leaving space for clamping.

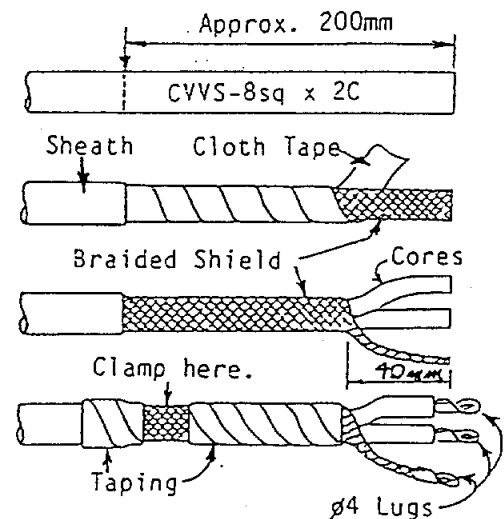

Fig.2-1 Fabricating the Power Cable

Fabricated Multicore Cable

Expose the braided shield of the multicore cable by removing the vinyl tape at the point shown in Fig.2-2.

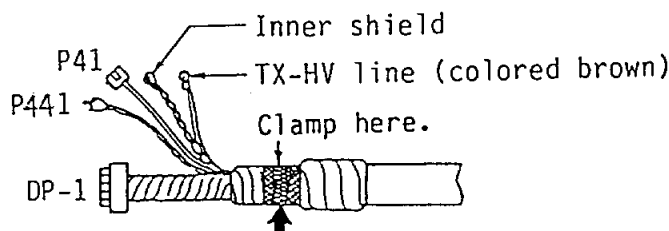

Fig.2-2 Multicore Cable (fabricated side)

Fabricating Non-terminated Multicore Cable (RW-6895)

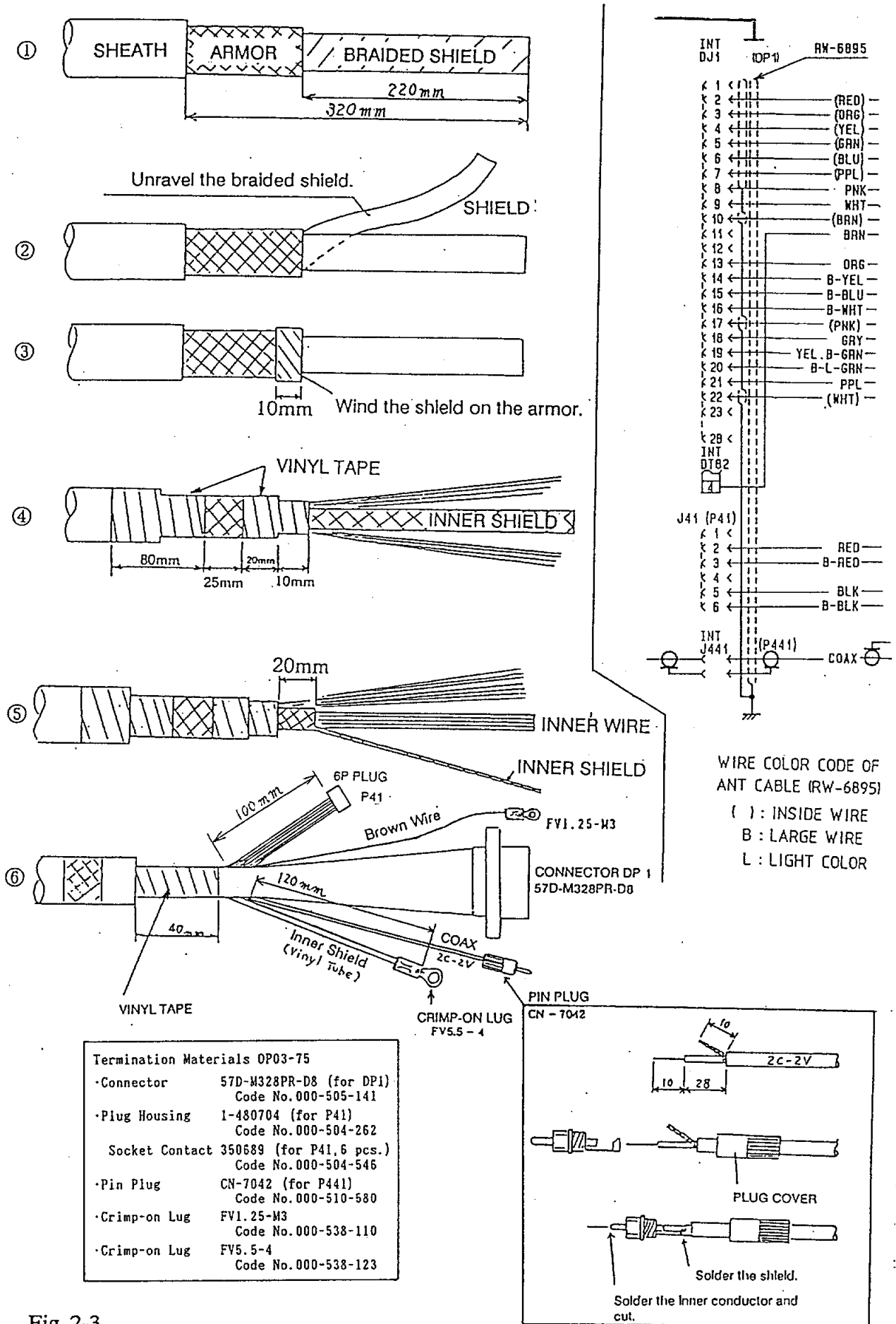

Fig. 2-3

Connections

- 1) Dismount the rear cover by loosening four M4x8 fixing screws.
- 2) Separate the clamping plate from the cable clamp by loosening two M4x10 fixing screws. Then secure the multicore cable and power cable so their cable shield is completely grounded through the clamp.
- 3) Fix cables of optional equipment by the cable clamp, by loosening two M6x35 hex head bolts.
- 4) Dress the end of the multicore cable through the cutout in the rear panel. Then connect:
 - coaxial cable plug P441 to jack J441 on the INT Board
 - multicore cable connector DP1 to jack DJ1 on the INT Board
 - 6P connector P41 to J41
 - Brown wire (crimp-on lug FV1.25-M3) to DTB2 #4 on the INT Board.
- 5) Ground the inner shield of the multicore cable to the chassis through a screw on the chassis.
- 6) Connect the power cable to terminal board DTB1; positive core to #1 and negative core to #2. Ground the shield of the power cable to the chassis through a screw on the chassis.
- 7) When incorporating built-in gyro converter (GC-7), connect the gyro signal to DTB3. If the bearing signal is supplied via external gyro converter (AD converter AD-100 etc.), connect the signal to J446. Use the 4P NH plug (P446) already attached to J446. When the speed log signal is available, connect it to J448. NH connector assembly 03-1499 (3P) for connection to J448 is contained in the installation materials.
- 8) Connect the ground wire (IV-8sq or equivalent) to the ground terminal.

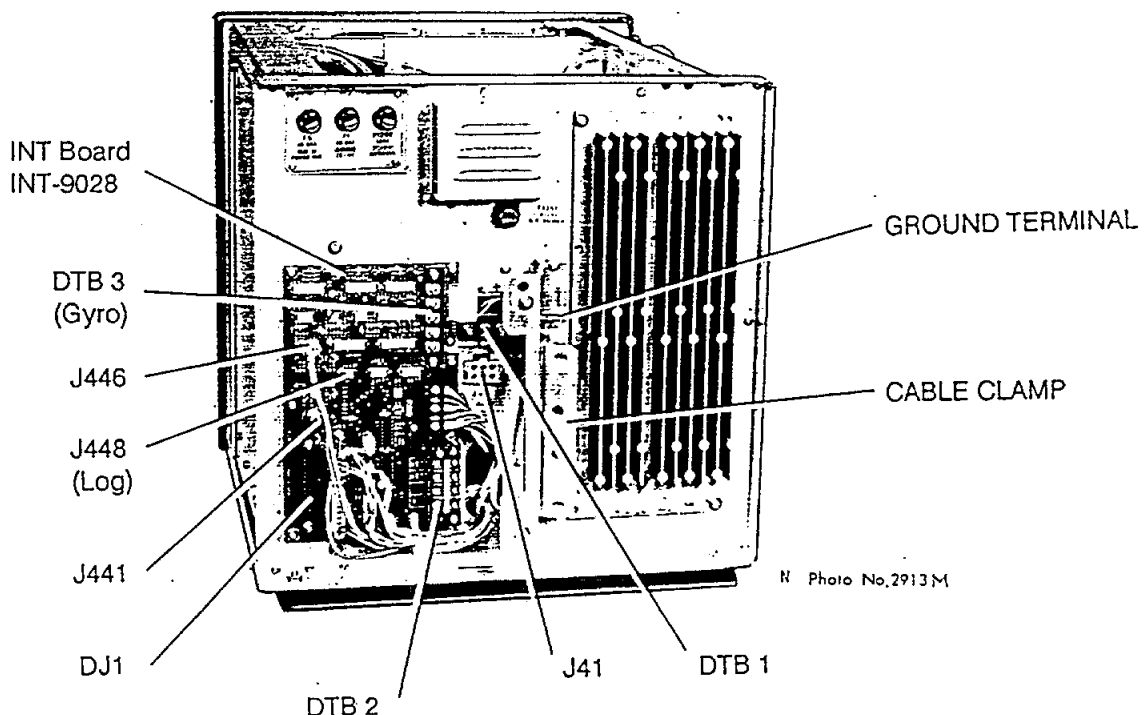

Fig. 2-4 Display Unit, rear view, cover removed

2.3 CONNECTIONS TO SCANNER UNIT

The signal cable (RW-6895) and the power cable for de-icer (if provided) are connected to the scanner unit.

Signal Cable RW-6895

- 1) Cut the cable to a suitable length, extending the length actually required by 600mm. Strip off about 600mm of the anti-corrosive vinyl sheath, and 590 mm of the armor and the inner vinyl sheath being careful not to nick the braided shield.

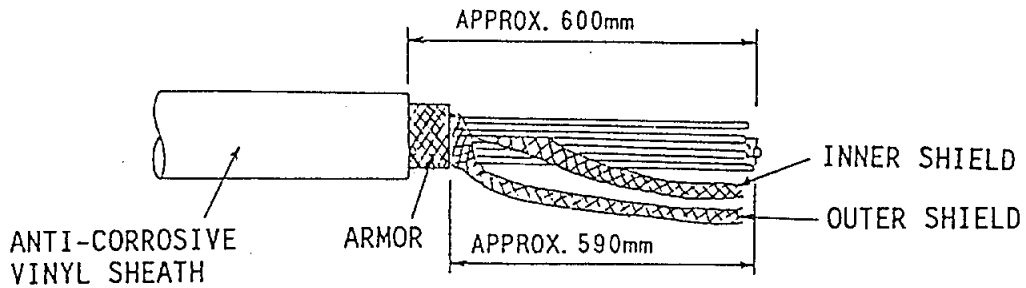

Fig.2-5 Fabricating the Signal Cable RW-6895

- 2) Untwine the outer braided shield with a screwdriver, etc. to expose the cores.
- 3) Similar to step 2, expose the cores under the inner shield. Appropriately mark the cores for future identification.
- 4) Slide the clamping gland, washers and rubber packing onto the cable. (Use lower side gland.)

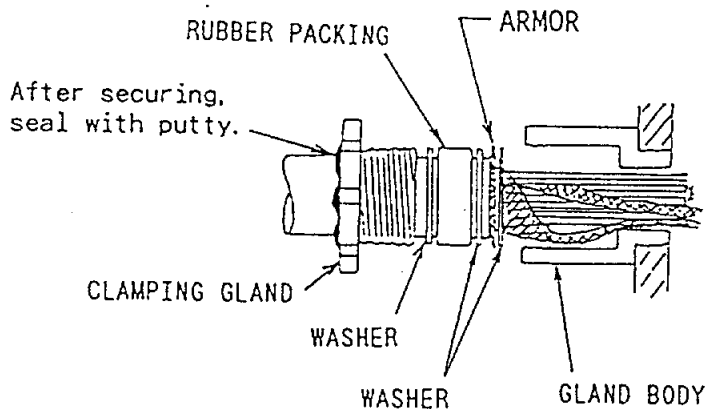

Fig.2-6

- 5) Ground the armor through the two washers as shown in Fig.2-6. Trim the shields considering their location on the earth terminal inside the scanner unit, fit a crimp-on lug (yellow, FV5.5-4 ϕ 4) to inner/outer shields, then connect to the ground terminal in the scanner unit.

- 6) Determine the length of each core considering its location on RTB801 (see the interconnection diagram on page S-1). Remove approx. 6mm of the vinyl insulation from the end of each core and fix the crimp-on lug (red, FV1.25-M3) to each core.
- 7) Remove the outer sheath of the coaxial cable (2C-2V) by 75mm and expose the inner core from the outer conductor (braided shield). Remove approx. 25mm of insulator from the end of inner core and fold back conductor as illustrated below. Cut the shield leaving approx. 45mm. Fit crimp-on lugs to the conductor and shield.

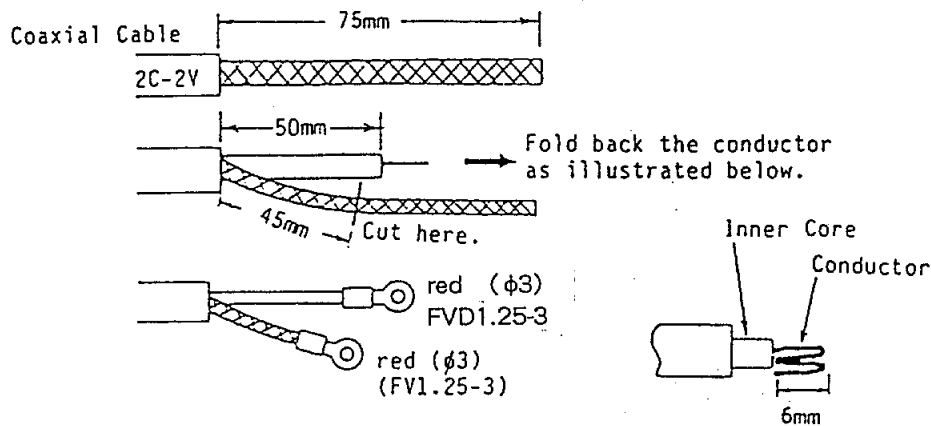

Fig.2-7 Processing the Core of the Coaxial Cable

- 8) Slip the cable gland over cable and tighten the cable gland nut. Seal the cable gland nut with putty to preserve watertight integrity.
- 9) Connect the conductors to terminal RTB801 according to the interconnection diagram.

De-icer Cable DPYCY-3.5 (Option)

- 1) Remove the vinyl sheath by 600mm and cut off the armor by 590mm.
- 2) Slide the clamping gland, washers and rubber packing onto the cable in the same manner as signal cable RW-6895. Then tighten the cable gland nut and seal with the putty. (Use upper side gland.)

When the de-icer is installed

- 1) Before beginning any work on the scanner unit, turn off the breaker for the de-icer line to remove the power (100VAC, 1 ϕ) to the de-icer. (Turning off the power to the display unit has no effect.)
- 2) The neck of the scanner unit becomes VERY HOT when the de-icer is working. (The de-icer turns on when ambient temperature is below 0°C.)

2.4 RECTIFIER UNIT INSTALLATION AND CONNECTION (OPTION)

For the operation from 100/110/115/220/230 VAC ship's mains, a rectifier unit is required. The unit can be mounted in any dry, well-ventilated place. The mounting dimensions are shown in the outline drawing.

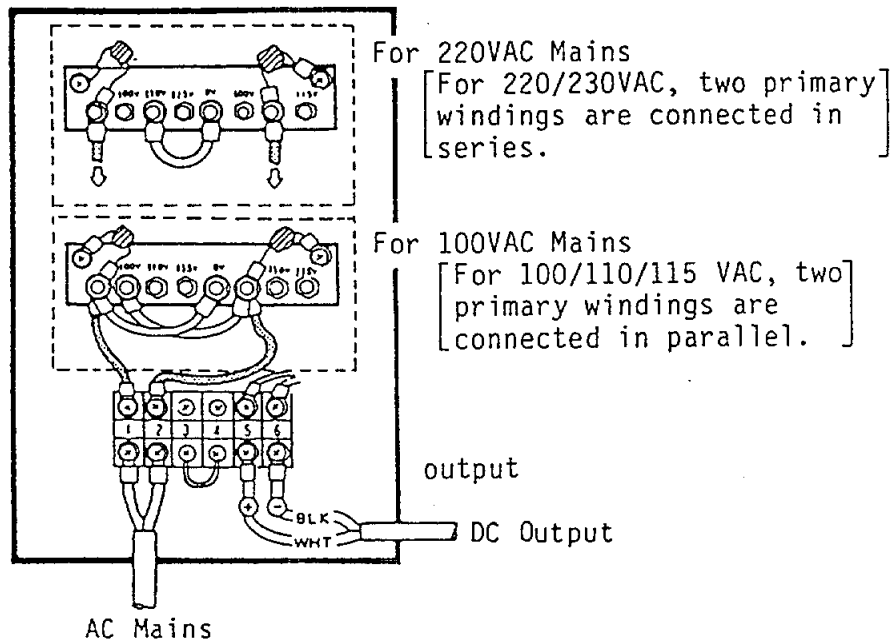

Fig.2-8 Connections to the Rectifier Unit

CHAPTER 3

POST INSTALLATION ADJUSTMENT

3.1 OPERATION CHECK

After completion of all wirings and interconnections, check that there is no wrong nor loose connection on the terminal boards. Check that the connectors and circuit boards are firmly connected to corresponding jacks and plugs. Then, perform the following operation check.

Step	Action				
1	<p>Set controls as follows:</p> <p>SCANNER switch*: ON BRILL, GAIN: fully CCW A/C SEA, A/C RAIN: fully CCW TUNE switch*: MAN(ual) TUNE potentiometer*: center Other controls: properly adjusted * In panel 3.</p>				
2	<p>a) Turn on the POWER switch. b) Measure input voltage is within rating.</p> <table style="width: 100%; border: none;"> <thead> <tr> <th style="text-align: left; border: none;"><u>Measuring point</u></th> <th style="text-align: left; border: none;"><u>Rating</u></th> </tr> </thead> <tbody> <tr> <td style="border: none;">Display Unit DTB1 #1(+) and #2(-)</td> <td style="border: none;">20.4V to 31.2VDC</td> </tr> </tbody> </table>	<u>Measuring point</u>	<u>Rating</u>	Display Unit DTB1 #1(+) and #2(-)	20.4V to 31.2VDC
<u>Measuring point</u>	<u>Rating</u>				
Display Unit DTB1 #1(+) and #2(-)	20.4V to 31.2VDC				
3	<p>a) Adjust screen brilliance with the BRILL control. b) After the radar has warmed-up (about 3 minutes) the indication ST-BY appears on the display.</p>				
4	<p>a) Confirm that there are no obstacles or persons near the scanner; then, press the [ST BY/TX] key. <u>NOTE</u>: The scanner starts rotating. b) Confirm that the scanner rotates 20-25 times/minute.</p>				
5	<p>a) Press the [ST BY/TX] key to return to stand-by condition and wait 15 minutes to allow magnetron oscillation to stabilize. b) While waiting for the magnetron to stabilize, measure magnetron heater voltage. (See "Magnetron heater voltage adjustment" on page 3-4.)</p>				
6	Press the [ST BY/TX] key about 10 times, stopping in transmit condition.				
7	Turn the GAIN control clockwise slowly. Echoes appear on the display.				
8	Transmit the radar on the 48 nm range.				
9	<p>Adjust the TUNE potentiometer so that a long range echo is discerned with maximum definition. <u>NOTE</u>: If maximum definition cannot be obtained with the potentiometer set at its mid travel see "Tuning adjustment" on page 3-9.</p>				
10	<p>a) Set the TUNE switch to the AUTO(matic) side. b) Confirm that the radar is properly tuned in 7 to 8 seconds. If not, tuning preset is necessary. See "Tuning adjustment" on page 3-9.</p>				
11	Operate all keys and controls one by one. Confirm that each operates properly.				

3.2 ADJUSTMENT PROCEDURE

The following adjustment should be made in order.

- 1) Magnetron heater voltage adjustment (R811/R812 in scanner unit)
- 2) Transmission timing adjustment (VR1 on SPU board)
- 3) Heading mark alignment (adjustment by menu)
- 4) Tuning adjustment (VR6 on Mother board)
- 5) MBS (Main Bang Suppression) adjustment (VR1/VR2 on Mother board)
- 6) Video STC ... Antenna height input (adjustment by menu)
- 7) Initial setting input (adjustment by menu)

Adjustment by menu

Several function can be tuned or adjusted through the menu. These include:

- Heading mark alignment
- Tuning preset
- Antenna height input
- Initial setting input

Adjustment of magnetron heater voltage requires transmitting the radar with antenna rotation suspended, in case of 30kW scanner unit. This also can be done through the menu.

The menus for installation purposes can be unlocked by turning on DIP switch S1 #4 on SPU board. After entering settings lock them by turning off the DIP switch. **THIS IS IMPORTANT TO PREVENT ACCIDENTAL ALTERATION OF SETTINGS.** (After the settings are locked these menus cannot be displayed without turning on the DIP switch.)

Panel 3

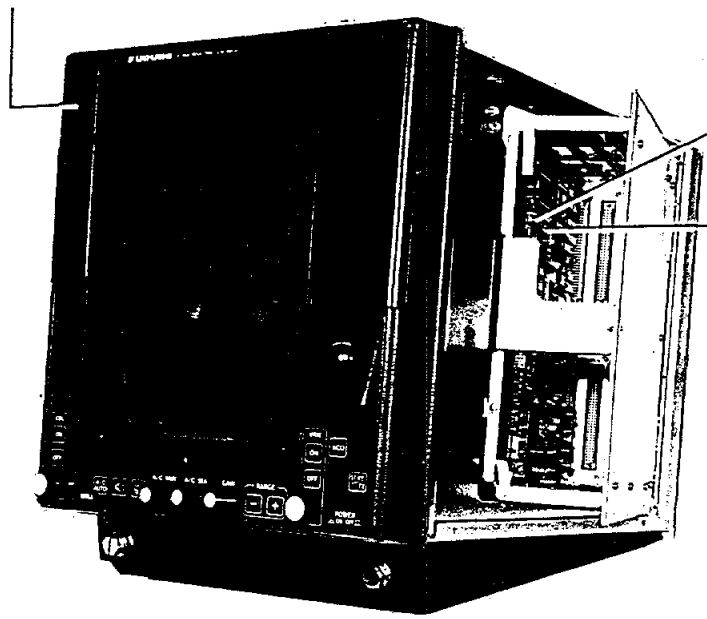

VR1 --- Trigger timing
(accessible from top of display unit)

DIP Switch S1 (behind VR1)
#1 --- OFF (for FR-1410DS)
ON (for FR-1430DS)
#2 --- OFF (without cursor gyro)
ON (cursor gyro spec.)
#3 --- OFF (for FR-1430DS)
ON (for FR-1410DS)
#4 --- EEPROM write protect
(initial setting protect)
OFF (locked)
ON (unlocked)

N Photo No.2924

Fig.3-1

VR1 --- MBS T
(main bang suppression time)

VR2 --- MBS L
(main bang suppression level)

VR6 --- Coarse Tuning

VR1 --- Trigger Timing

GYRO PROCESSOR
Board (optional)
Refer to page A-9.

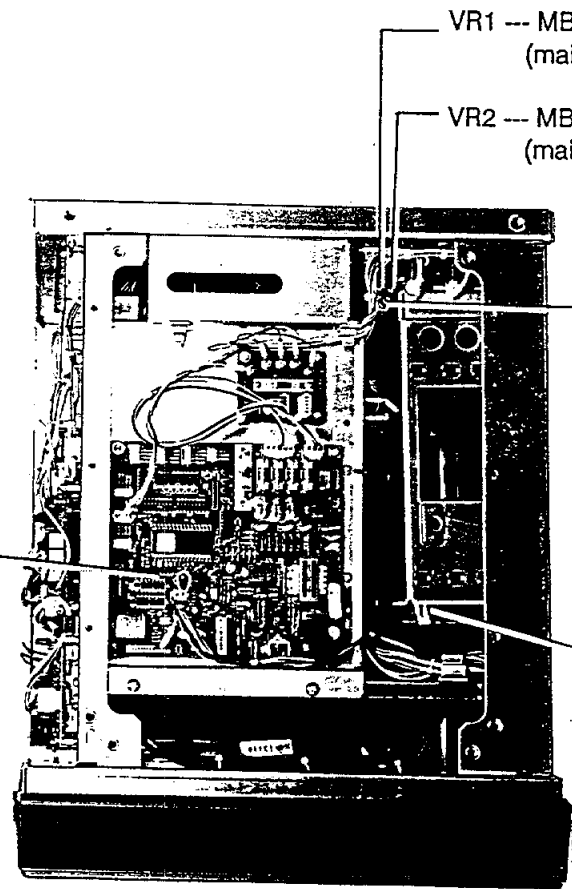

N Photo No.2930

Fig.3-2 Location of Potentiometer

3.3 MAGNETRON HEATER VOLTAGE ADJUSTMENT

The magnetron heater voltage has been adjusted at the factory using the standard scanner cable length (15 m). Even if the standard length is used confirm voltage by the following procedure.

Step	Action
1*	Do the following to "transmit" the radar with antenna rotation suspended: (for FR-1430DS only) a) Turn the radar off. b) Turn on the #4 switch of DIP switch S1 on the SPU Board. c) Turn the radar on. d) Press the [MENU] key (panel 1) to display the FUNCTIONS menu. e) Press the [0] key to display the SYSTEM SETTING menu. f) Press the [8] key to select INITIAL SETTING 1. g) Press the [9] key. h) Press the [9] key again to select TX. i) Press the [ENTER] key.
2	Set the radar to stand-by.
3	Turn off the SCANNER switch.
4	Set the range to 0.25 nm.
5	Turn the BRILL control fully counterclockwise (minimum brilliance).
6	Connect the multimeter, set to the 10 VDC range, between T801 #4 (+, green lead) and #6 (-, yellow lead) in the Scanner Unit.
7	Adjust the position of the sliding contact of R812 to obtain a multimeter reading as follows. 7.3 to 7.9V FR-1410DS (10kW) 6.0 to 6.6V FR-1430DS (30kW)
8*	Remove the TX-HV fuse (F1, 0.5 A) on the rear panel of Display Unit.
9*	Transmit the radar on the 48 nm range.
10*	Adjust the position of the sliding contact of R811 to obtain the multimeter reading between 5.1 and 5.5V.
11*	Reinsert TX-HV fuse.
12*	At INITIAL SETTING 1 menu, press the [9] key to select ST-BY.
13*	Press the [ENTER] key.
14	Turn off the power.
15*	Turn off the #4 switch of DIP switch S1 on the SPU Board.

*: Required for FR-1430DS (30kW) only.

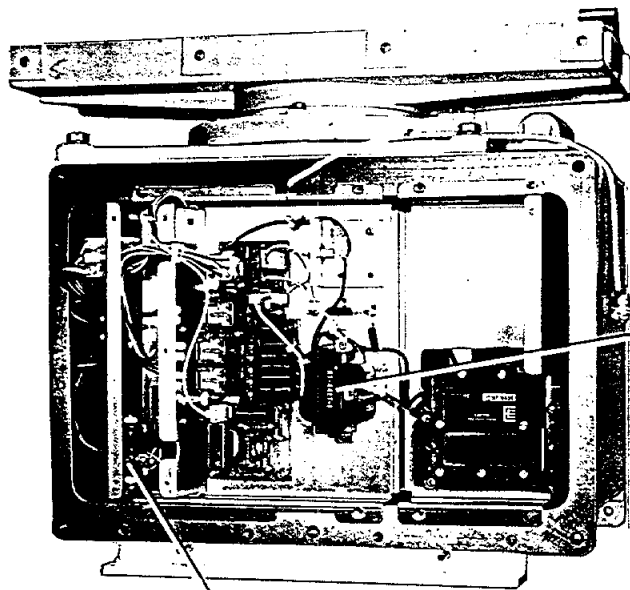

Pulse Transformer T801
 check of magnetron
 heater voltage
 #4 (+, green lead wire)
 #6 (-, yellow lead wire)

N Photo No,2079

R812 --- Heater Voltage Adjustment

Fig.3-3 10kW Scanner Unit (for FR-1410DS)

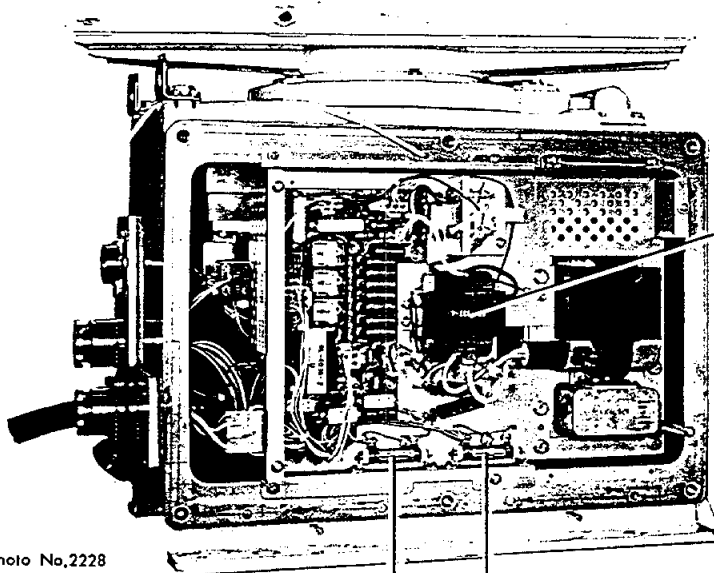

Pulse Transformer T801
 check of magnetron
 heater voltage
 #4 (+, green lead wire)
 #6 (-, yellow lead wire)

N Photo No,2228

R811 --- Heater Voltage Adj. (long pulse)

R812 --- Heater Voltage Adj. (short pulse)

Fig.3-4 30kW Scanner Unit (for FR-1430DS)

3.4 TRANSMISSION TIMING ADJUSTMENT

Transmission timing differs with respect to the length of the multicore cable between display and the scanner units. Even if the standard cable of 15m in length is used, the adjustment must be performed. The following problems may occur if the adjustment is not made.

- * Straight wharf or breakwater appears bent inward or outward at the center of the screen on 0.25 nm range.
- * Range error is found on short range.
- * Dark area appears at the center of the screen.

The adjustment is made with VR1 (TIMING) on the SPU board while observing the radar screen.

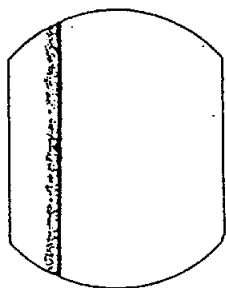

a. PROPER SETTING
Straight target
appears as a
straight line
on the screen.

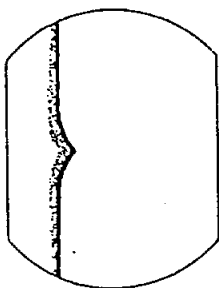

b. Straight target
is pulled inward.

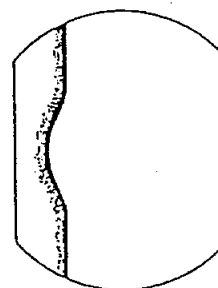

c. Straight target
is pushed outward.

Fig. 3-5 Transmission Timing

3.5 HEADING MARK ALIGNMENT

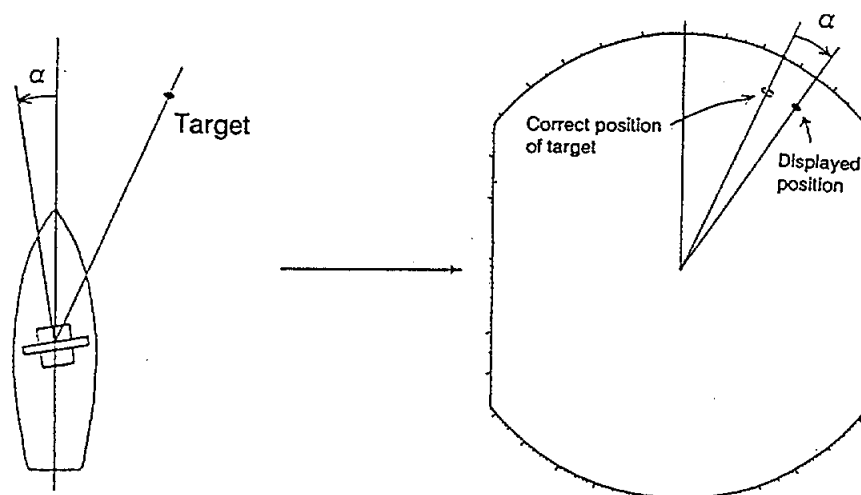

Scanner unit mounting error
Port side
(Advanced heading switch timing)

Picture shifts clockwise
(Plus error)

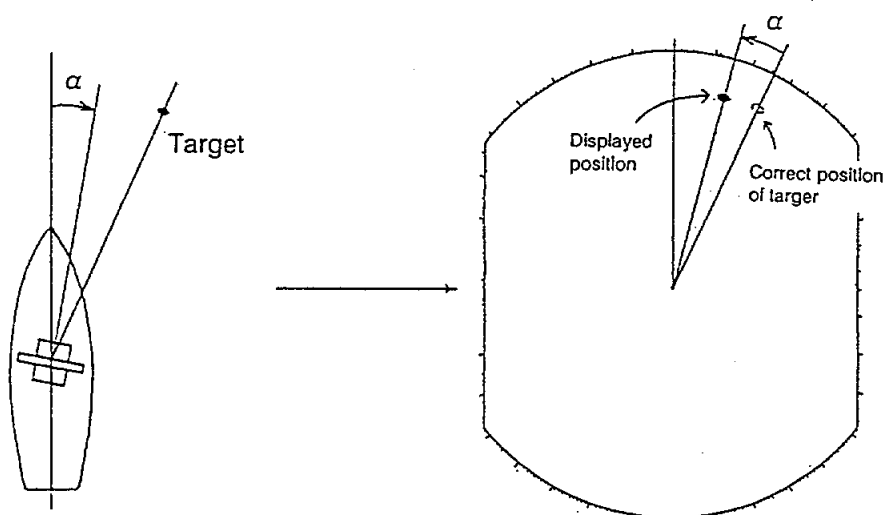

Scanner unit mounting error
starboard side
(Delayed heading switch timing)

Picture shifts counter-clockwise
(Minus error)

The scanner unit mounting error (heading switch timing error) can be compensated in the display unit for all directions ($\pm 180^\circ$).

The heading alignment is made with the initial setting menu. The initial setting menu is usually not displayed on the screen to avoid accidental alteration of settings. To display the initial setting menu, turn on the dip switch S1 #4 on SPU board 03P9018 to unlock the initial setting menu.

After completing the adjustment with the initial setting menu, do not forget to return the dip switch S1 #4 to "OFF" side.

Press [MENU] key.
(Functions Menu)

[FUNCTIONS]		
1	ECHO STRETCH	OFF/1/2
2	IDX LINE	OFF/ON
3	TRAIL TIME	30S/1M/3M/6M/30M/CONT
4	PULSE WD	1/2
5	ECHO AVG	OFF/1/2/3
6	INT REJ	OFF/ON
7	PANEL BRIL	OFF/DIM/M/BRT
8	CHAR BRIL	DIM/M1/M2/BRT
9	TRAIL ERASE	
0	[SYSTEM SETTING]	

Press [0] key.
(System Setting Menu)

[SYSTEM SETTING]	
1	[FUNCTIONS]
2	RADAR FUNCTIONS
3	VIDEO PLOTTER
4	AUTO PLOTTER
5	FUNCTION KEY1
6	FUNCTION KEY2
7	
8	INITIAL SETTING
9	TEST
0	

Press [8] key.
(Initial Setting Menu)

[INITIAL SETTING 1]		
1	[SYSTEM SETTING]	
2	HD ALIGN	
3	ANT HGT	6M/10M/20M
4	[PULSE WD 1]	MORE
5	[PULSE WD 2]	
6	ON TIME	000000.0
7	TX TIME	000000.0
8	ECHO AVG	OFF/ON
9	W/O GYRO	
9	SCANNER	ST-BY/TX
	STOPPED	
0	[INITIAL SETTING 2]	

Press [2] key. (Heading Alignment Mode)

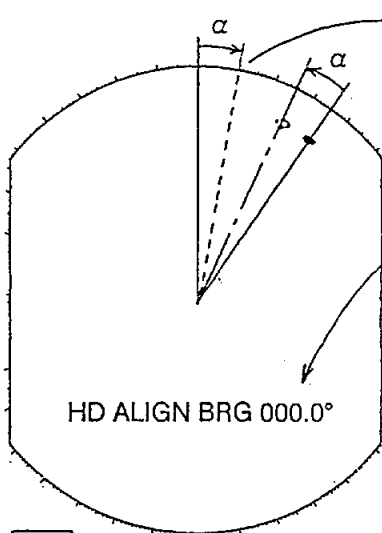

Move the EBL to the correct heading position. (Any of EBL 1 or EBL2 can be used.) This EBL position becomes the new heading position, that is, the picture shifts counter-clockwise by α° .

This value shows the present compensation value of heading timing. If this value coincides with actual heading switch timing (bearing relative to ship's heading), the picture will be correctly displayed on the screen. For example, if the heading switch timing is advanced by 5° (heading switch actuates at 355° relative to the ship's heading), set this value to 355° .

EBL reading displayed here is unconcerned for heading mark alignment.

Press [ENTER] key. (Heading error compensated radar picture)

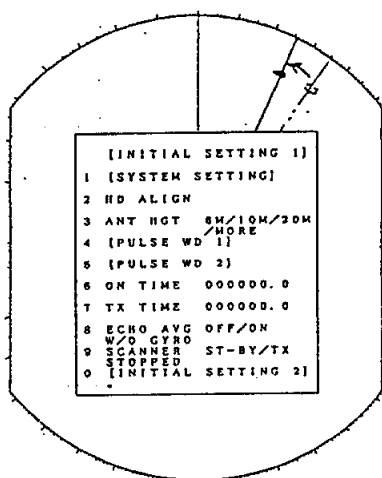

Pressing the [ENTER] key again erases the pop-up menu 3 seconds for ease of radar picture observation. This facility can be repeatedly used.

If the heading error remains due to insufficient compensation, return to heading align mode again by pressing the [2] key and repeat the adjustment until the error is completely corrected.

Press [MENU] key to return to normal operation mode.

3.6 TUNING ADJUSTMENT

If the radar is not automatically tuned with the TUNE switch set to AUTO, the following tuning preset is required.

Step	Action
1	Open panel 3 and turn the TUNE switch to MAN.
2	Transmit the radar on the 48 nm range.
3	Set controls and switches as follows: GAIN & BRILL: properly adjusted A/C SEA, A/C RAIN: fully counterclockwise TUNE potentiometer: center position
4	Adjust VR6 (TUNE) on the MOTHER Board to display longest tuning bar.
5	Set the TUNE switch to AUTO.
6	Wait until the radar is tuned (7 to 8 seconds).
7	Select the TUNE ADJ menu and press the [ENTER] key. With this action, the automatic tuning preset is completed.
8	Confirm that about five tuning bars light. If less than five light, turn the TUNE switch to MAN and repeat the steps 4 thru 7.
9	Press the [MENU] key.

3.7 MBS (MAIN BANG SUPPRESSION) ADJUSTMENT

MBS has been adjusted at the factory. Confirm that the main bang is suppressed, after adjusting transmission timing.

Step	Action
1	Transmit the radar on long range and wait 10 minutes.
2	Adjust the GAIN control so a slight amount of noise is visible on the screen.
3	Set the range to 0.25 nm.
4	Adjust the A/C SEA control to suppress sea clutter.
5	Turn VR1 (MBS Timing) and VR2 (MBS Level) on the MOTHER Board fully clockwise.
6	Turn VR1 on the MOTHER Board counterclockwise, slowly until the main bang disappears.
7	Turn VR2 on the MOTHER Board counterclockwise slowly until the main bang is faintly visible.
8	Turn the VR1 again counterclockwise slowly until the main bang just disappears.

NOTE: Too high a setting of MBS will cause the target echo in close ranges to disappear.

3.8 VIDEO LEVEL AND VIDEO STC ... ANTENNA HEIGHT INPUT

The STC curve change with the antenna height above the waterline. Enter the vessel's antenna height above the waterline through the menu.

Step	Action
1	Confirm that DIP switch S1 #4 on the SPU Board is on.
2	Press the [MENU] key to display the FUNCTIONS menu.
3	Press the [0] key to select SYSTEM SETTING.
4	Press the [8] key to select INITIAL SETTING.
5	Press the [3] key to select ANT HGT.
6	Select antenna height by pressing the [3] key. 6M: 6 m or less 10M: 6 – 10 m 20M: 10 – 20 m MORE: 20 m or more
7	Press the [ENTER] key.
8	Press the [MENU] key.
9	Readjust the A/C SEA control and confirm that sea clutter is reduced properly.

NOTE: Do not adjust rotary coded switches S1, S2 and S3 on the VIDEO AMP Board. (Factory Settings are all "0".)

VIDEO AMPLIFIER LEVEL

When the signal cable is very long, the video amplifier input level decreases, shrinking target echoes. To prevent this, confirm (and adjust if necessary) video amplifier input level.

1. Transmit the radar on the 12 mile range.
2. Measure video amplifier input level on the VIDEO AMP Board (VDA-9096) in the display unit as directed in the table which bellows.

Check point	Rating	Measuring Conditions
TP3 (take trigger at TP10)	4Vpp \pm 0.1 V	AC RAIN: fully ccw A/C AUTO: OFF

3.9 INITIAL SETTING MENU

Besides the Heading Mark Alignment and Antenna Height input, various settings can be entered through the initial setting menus. To display the initial setting menu, turn on the DIP switch S1 #4 on SPU board 03P9018 to unlock the initial setting menus. After entering settings, lock them by turning off the DIP switch S1 #4. This is important to prevent accidental alteration of settings.

NOTE: The initial setting data is registered in EEPROM (U11) on SPU board. When replacing the SPU board with new one, interchange the EEPROM with that used formerly so that the re-entering of the initial setting can be omitted.

Below are the INITIAL SETTING 1, 2 and 3 screens.

Initial Setting 1 Screen

```

[INITIAL SETTING 1]
1 [SYSTEM SETTING]
2 HD ALIGN
3 ANT HGT 6M/10M/20M
4 [PULSE WD 1]
5 [PULSE WD 2]
6 ON TIME 000000.0
7 TX TIME 000000.0
8 ECHO AVG OFF/ON
  W/O GYRO
9 SCANNER ST-BY/TX
  STOPPED
0 [INITIAL SETTING 2]
  
```

- Returns to [SYSTEM SETTING] screen.
- Heading Alignment.
- Antenna Hight.
- To PULSE WD 1 screen.
- To PULSE WD 2 screen.
- No. of hours radar turned on
- No. of hours radar transmitted
- Echo averaging without gyro
- Enable transmission with scanner rotation suspended

Initial Setting 2 Screen

```

[INITIAL SETTING 2]
1 [INITIAL SETTING 1]
2 KEY BEEP OFF/ON
3 LOG PLS 0000PLS
4 VID SIG ANLG/DGTL
5 ALM LVL 4/5/6/7
6 INT REJ 1/2/3
7 DISPLAY MAIN/SUB
8 TUNE ADJ
9 DEFAULT SETTINGS
0 [INITIAL SETTING 3]
  
```

- Returns to [INITIAL SETTING 1] screen.
- Key Response Tone
- Log Pulse
- Video Signal
- Guard Alarm Signal Level
- Interference Rejection
- Display Selection
- Tuning Adjustment
- Restores Default Settings

Initial Setting 3 Screen

```

[INITIAL SETTING 3]
1 [INITIAL SETTING 2]
2 TRAIL W/ OFF/ON
  HLDG RNG
3 CURSOR DEGS/8PTS
  GYRO DISP
4 ES ON OFF/ON
  SHRT RNG
5
.
.
0
  
```

- For echo trailing
- For gryo-linked bearing scale
- For short range echo enhancement

procedure

Here is the basic procedure for entering initial setting. All keys mentioned in the procedure are in panel 1.

Step	Action	Resulting Display
1	Press the [MENU] key.	FUNCTIONS menu appears.
2	Press the [0] key to select SYSTEM SETTING.	SYSTEM SETTING menu appears.
3	Press the [8] key to select INITIAL SETTING.	INITIAL SETTING 1 menu appears.
4	Press numeral key corresponding to initial setting you want to set.	The menu item number appears in reverse video.
5	Press the same numeral key pressed in step 4 to select setting.	
6	Press the [ENTER] key.	
7	Repeat steps 4, 5 and 6 to enter other settings.	
8	Press the [0] key to select INITIAL SETTING 2 menu.	The INITIAL SETTING 2 menu appears.
9	Do steps 4 and 5 above to select setting.	
10	Press the [ENTER] key.	
11	Repeat steps 4, 5 and 6 to enter other settings.	
12	Press the [MENU] key.	Control is returned to the radar display.
13	AFTER ENTERING ALL INITIAL SETTINGS, LOCK ALL SETTINGS BY TURNING OFF DIP SWITCH S1#4.	

PULSE WD (Transmission Pulsewidth)

Two sets of pulsewidths for the range between 0.75nm and 24nm can be registered. Reselect the pulsewidth for respective ranges, if necessary, on PULSE WD 1 and PULSE WD 2 menus.

ON TIME/TX TIME

The numbers of hours radar has been turned on and radar has been transmitted are displayed on ST-BY screen. These data are useful for maintenance such as magnetron replacement. The TX TIME may be reset to zero when replacing the magnetron.

ECHO AVG W/O GYRO

The true echo average is ineffective without gyro signal. If echo averaging without gyro (relative echo average) is required, the echo average can be turned on compulsorily through this menu.

KEY BEEP (Key Response Tone)

Turns key beep response tone on or off.

LOG PLS (Log Pulse)

Selects number of log pulse of connected speed log.

VID SIG (Video Signal)

Selects video signal: analog or digital. Set to digital to adjust quantized video for optional Auto Plotter ARP-21. Return to the analog setting after adjusting.

ALM LVL (Guard Alarm Signal Level)

Selects signal level of radar targets which will trigger guard alarm. The "7" setting will give the alarm to the strongest echo.

INT REJ (Interference Rejection)

Selects radar interference rejection level. Level 1 is the weakest.

DISPLAY (Display Selection)

Use display unit as main or slave. For slave display, the following signal input is required.

Heading Signal ... to DJ1 #21
Bearing Signal to DJ1 #22
Trigger Signal to DJ1 #28
Video Signal to J441 (pin jack)

DEFAULT SETTINGS

To restore default settings, select this menu and press the [ENTER] key. Then turn off and on the power. Refer to next page for default settings.

TRAIL W/ HLDG RNG (Restart of trailing when the range is changed)

Selects suspending or restarting of trailing when the range is changed while echo trail is on.

CURSOR GYRO DISP (Gyro-linked Bearing Scale)

Selects 30 degree step digital display or 8 principal points display (N, NE, E ...) on the gyro-linked bearing scale.

ES ON SHRT RNG (Enlargement of Short Range Echo)

When this menu is set to ON, short range echoes within 1/6 of radius are enhanced on 3, 6 and 12 nm range settings.

FR - 1410DS/1430DS MENU LIST (Reverse video shows default setting) 1/3

[FUNCTIONS]

1 ECHO STRETCH **OFF**/1/2

2 IDX LINE **OFF**/ON

3 TRAIL TIME OFF/30S/1M/**3M**/
6M/15M/30M/CONT

4 PULSE WD **1**/2

5 ECHO AVG **OFF**/1/2/3

6 INT REJ OFF/**ON**

7 PANEL BRIL OFF/DIM/**M**/BRT

8 CHAR BRIL DIM/M1/**M2**/BRT

9 TRAIL ERASE

0 [SYSTEM SETTING]

[SYSTEM SETTING]

1 [FUNCTIONS]

2 RADAR FUNCTIONS

3 VIDEO PLOTTER

4 AUTO PLOTTER

5 FUNCTION KEY1

6 FUNCTION KEY2

7

8 INITIAL SETTING

9 TEST

0

[RADAR FUNCTIONS 1]

1 [SYSTEM SETTING]

2 IDX LINE **VRM2**/MAN
INTVL 00.50NM

3 EBL1 **REL**/TRUE

4 EBL2 **REL**/TRUE

5 VRM1 **NM**/km

6 VRM2 **NM**/km

7 TRAIL REL/**TRUE**

8 SHIP SPD **LOG**/MAN
00.0KTS

9 HM BRIL DIM/**BRT**

0 [RADAR FUNCTIONS 2]

[RADAR FUNCTIONS 2]

1 [RADAR FUNCTIONS 1]

2 ECHO **MONO**/COLOR

3 TRAIL SGL/**MULTI**
GRADATION

4 RNG UNIT **NM**/km

5 STERN MK **NO**/YES

6 ALARM **IN**/OUT

7 + CURSOR OFF/**ON**

8 + CURSOR **REL**/TRUE

9 2ND ECHO **OFF**/ON

0 NOISE REJ **OFF**/ON

[FUNCTION KEY1]

1 [SYSTEM SETTING]

2 INT REJ OFF/1/2/**3**

3 ECHO STRETCH **OFF**/1/2

4 ECHO AVG OFF/1/2/**3**

5 A/C AUTO **OFF**/ON

6 [FUNC 1 PULSE WD]

7 DSP CHAR F1/F2/RIV/BY/
SHP/**BRD**/SR/LR

8 NOISE REJ **OFF**/ON

9

0

[FUNC 1 PULSE WD]

1 [FUNCTION KEY1]

2 0.75~1.5 NM **S**/**M1**
1.5~3 km

3 3 NM **M1**/**M2**

6 km

4 6~24 NM **M2**/**L**
12~48

5

6

7

8

9

0

[FUNCTION KEY2]

1 [SYSTEM SETTING]

2 INT REJ OFF/1/2/3

3 ECHO STRETCH OFF/1/2

4 ECHO AVG OFF/1/2/3

5 A/C AUTO OFF/ON

6 [FUNC 2 PULSE WD]

7 DSP CHAR F1/F2/RIV/BY/
 SHP/BRD/SR/LR

8 NOISE REJ OFF/ON

9

0

[FUNC 2 PULSE WD]

1 [FUNCTION KEY2]

2 0.75~1.5 NM S/M1
 1.5~3 km

3 3 NM M1/M2
 6 km

4 6~24 NM M2/L
 12~48 km

5

6

7

8

9

0

[INITIAL SETTING 1]

1 [SYSTEM SETTING]

2 HD ALIGN

3 ANT HGT 6m/10m/20m/
 MORE

4 [PULSE WD 1]

5 [PULSE WD 2]

6 ON TIME 000000.0

7 TX TIME 000000.0

8 ECHO AVG OFF/ON
 W/O GYRO

9 SCANNER ST-BY/TX
 STOPPED

0 [INITIAL SETTING 2]

[PULSE WD 1]

1 [INITIAL SETTING 1]

2 0.75~1.5 NM S/M1
 1.5~3 km

3 3 NM M1/M2
 6 km

4 6~24 NM M2/L
 12~48 km

5

6

7

8

9

0

[PULSE WD 2]

1 [INITIAL SETTING 1]

2 0.75~1.5 NM S/M1
 1.5~3 km

3 3 NM M1/M2
 6 km

4 6~24 NM M2/L
 12~48 km

5

6

7

8

9

0

FR - 1410DS/1430DS MENU LIST (Reverse video shows default setting) 3/3

[INITIAL SETTING 2]	
1	[INITIAL SETTING 1]
2	KEY BEEP OFF/ ON
3	LOG PLS 0200 PLS
4	VID SIG ANLG /DGTL
5	ALM LVL 4/ 5 /6/7
6	INT REJ 1/2/ 3
7	DISPLAY MAIN /SUB
8	TUNE ADJ
9	DEFAULT SETTINGS
0	[INITIAL SETTING 3]

[INITIAL SETTING 3]	
1	[INITIAL SETTING 2]
2	TRALL W/ OFF /ON HLDG RNG
3	CURSOR DEGS /8PTS GYRO DSP
4	ES ON OFF /ON SHRT RNG
5	
6	
7	
8	
9	
0	

• with built - in Video Plotter RP - 21

[VIDEO PLOTTER]	
1	[SYSTEM SETTING]
2	GRIDS DIM/M1/ M2 BRIL BRT
3	TRACK DIM/M1/ M2 BRIL BRT
4	CHART DIM/M1/ M2 BRIL BRT
5	MARK DIM/M1/ M2 BRIL BRT
6	CHAR DIM/M1/ M2 BRIL BRT
7	
8	
9	
0	

• with built - in Auto Plotter ARP - 21

[AUTO PLOTTER]	
1	[SYSTEM SETTING]
2	INTERVAL 15S/30S/1M /2M/ 3M /6M/10M/12M
3	HISTORY 0/ 5 /10 POINTS
4	DISPLAY DIM/M1/ M2 BRIL BRT
5	
6	
7	
8	
9	
0	

3.10 SETTING FOR CURSOR GYRO MODE

When adding the cursor gyro, turn the DIP switch S1 #2 on SPU board to "ON" side.

3.11 SELF TEST

This radar has self test facilities to check it for proper operation. The self test checks:

- ROM 1 (U58) on the SPU Board
- ROM 2 (U59) on the SPU Board
- RAM 1 (U76) on the SPU Board
- RAM 2 (U77) on the SPU Board
- Keys
- Displays DIP switch (S1) settings

The table below shows how to conduct the self test.

Step	Action	Resulting Display
1	Turn on DIP switch S1 #4.	
2	Turn on the POWER switch.	
3	Press the [MENU] key.	The FUNCTIONS menu appears.
4	Press the [0] key to select SYSTEM SETTING.	The SYSTEM SETTING menu appears.
5	Press the [9] key to select TEST.	The TEST display appears. (See figure on the next page.)
6	Press each key one by one, pressing the [MENU] key last.	The key's corresponding location on the display lights if the key is functioning properly.
7	Press the [MENU] key to quit the test.	The radar display appears.

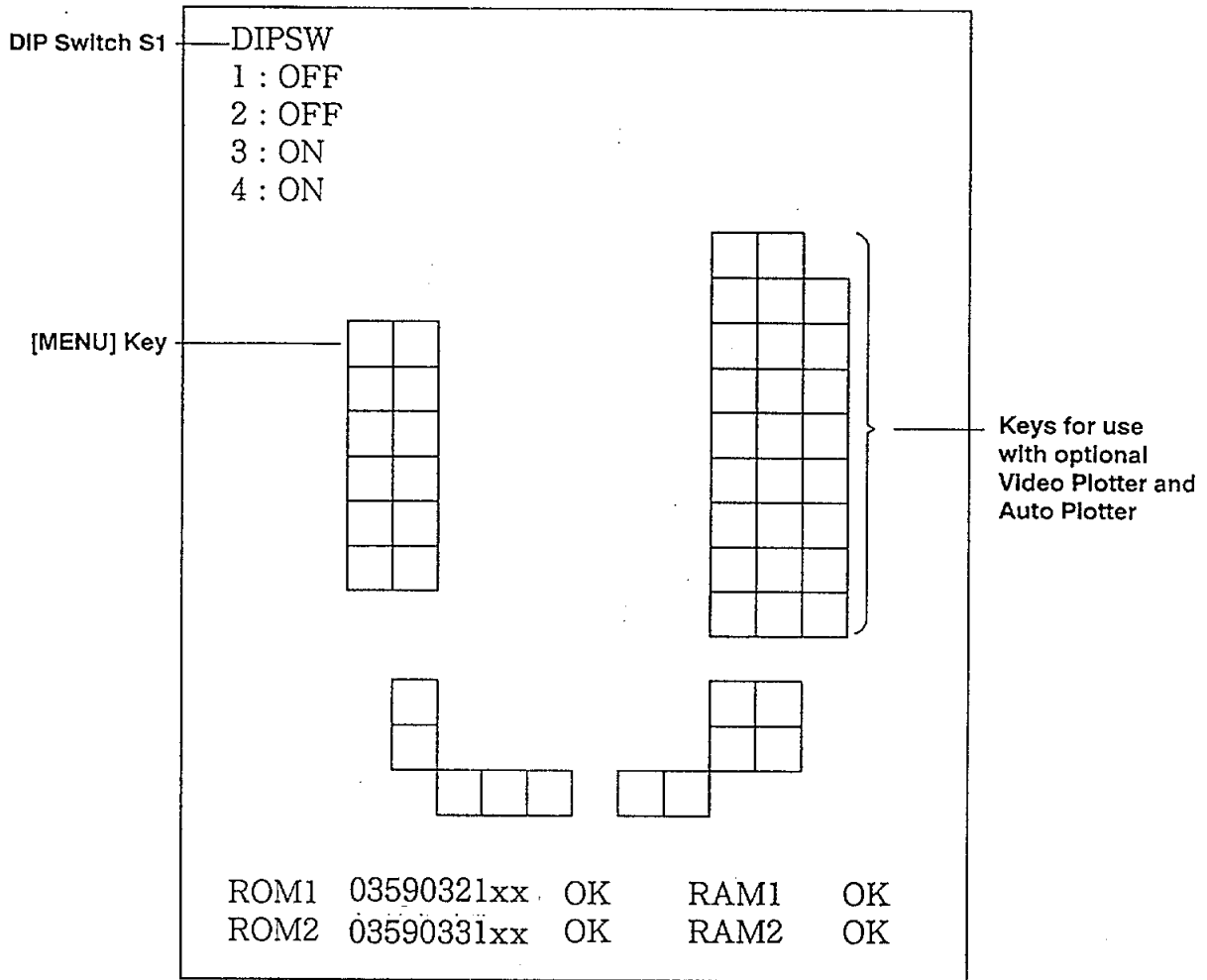

Self Test Display

DIP Switch Settings

DIP Switch S1 Models	#1	#2	#3	#4
FR-1410DS	OFF	OFF/ON	ON	OFF/ON
FR-1430DS	ON	OFF/ON	OFF	OFF/ON

↑
 "ON" for Cursor Gyro Specification.

↑
 Usually set to "OFF".
 "ON" for Initial Setting and Self Test Display.

APPENDIX A

SETTING OF GYRO CONVERTER GC-7

The GC-7 Gyro Converter, built in the display unit of the FR-1400 series radars, converts the analog gyrocompass reading into digital coded bearing data for display on the radar display.

This chapter explains how to set up the GC-7 according to the make and specifications of the gyrocompass connected.

Connection of External Power Supply

An external power supply is required when a DC step-by-step gyrocompass is used since it cannot supply 5 W or 20 V.

Jumper wire

If an external power supply is used remove jumper wire JP1.

Connections

Connect cables as shown below.

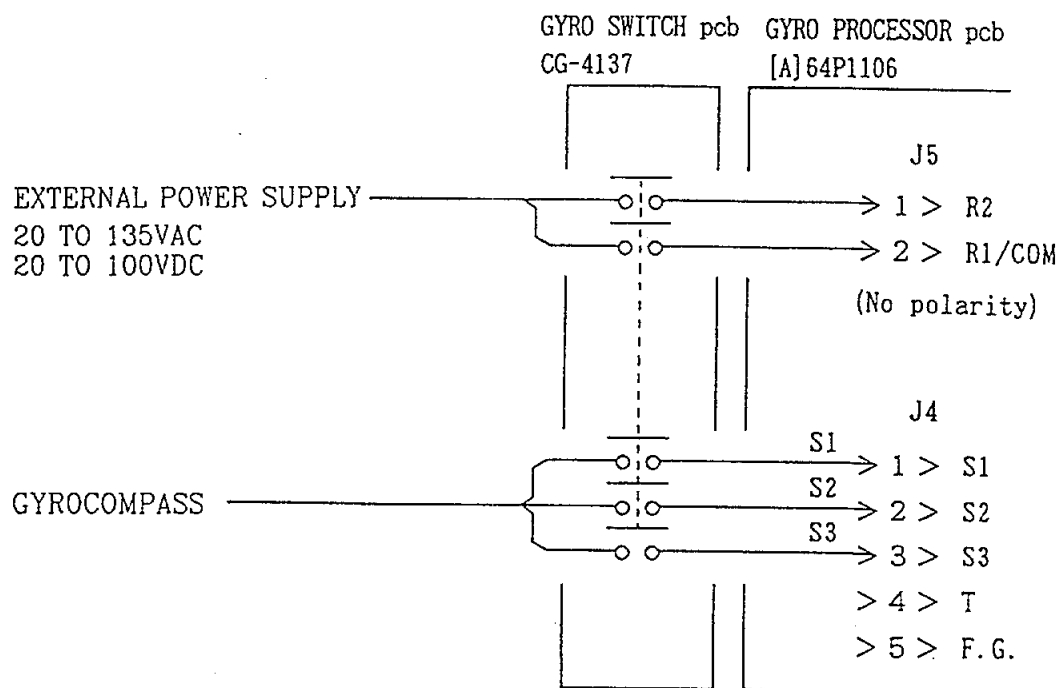

Figure A-1 Connection of External Power Supply

Compatible Gyrocompasses

The GC-7 is compatible with most gyrocompasses by means of its DIP switches and jumper wires. Below are the specifications of the gyrocompass it can accommodate.

AC synchro

Frequency: 50/60 Hz, 400 Hz, 500 Hz
Rotor Voltage: _____ VAC
Stator Voltage : _____ VAC
Gear Ratio: 360x, 180x, 90x, 36x

DC synchro

Rotor Voltage: _____ VDC
Stator Voltage: _____ VDC
Gear Ratio: 360x, 180x, 90x, 36x

DC step-by-step

Supply Voltage: _____ VDC
Gear Ratio: 360x, 180x, 90x, 36x

Full-Half-wave pulsating current

Frequency: 50/60 Hz, 400 Hz, 500 Hz
Supply Voltage: _____ VDC
Gear Ratio: 360x, 180x, 90x, 36x

Full-wave pulsating current

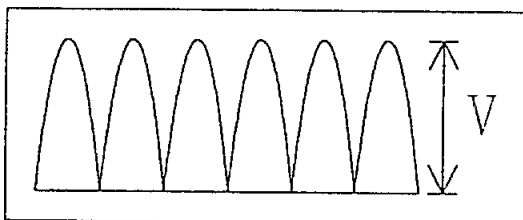

Half-wave pulsating current

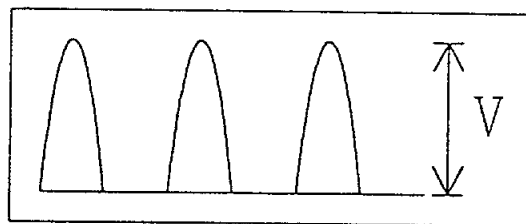

Setting the DIP Switches and Jumper Wires

DIP switch and jumper wire factory settings

In the factory settings all DIP switches are OFF and jumper wire #1 is connected, provided that JP1 is set to #1, #2, #3. In this setting the following gyrocompass can be directly connected without further modification.

Gyrocompass: AC synchro
Frequency: 50/60 Hz
Rotor voltage: 60 to 135 VAC
Stator voltage: 60 to 135 VAC
Gear ratio: 360x
Supply voltage: 30 to 135 VAC

Setting procedure

1. Setting of gyrocompass type

Gyrocompass	SW1-4	SW1-5	SW1-6	JP1
AC Synchro	OFF	OFF	OFF	#1, #2, #3
DC Synchro	OFF	OFF	OFF	#2, #3, #4
DC step-by-step	ON	OFF	OFF	#4, #5, #6
Fullwave pulsating current	OFF	ON	OFF	#4, #5, #6
Halfwave pulsating current	ON	ON	OFF	#4, #5, #6

2. Setting of frequency

Frequency	SW1-7	SW1-8	Remarks
50/60 Hz	OFF	OFF	AC synchro, pulsating current
400 Hz	ON	OFF	AC synchro, pulsating current
500 Hz	OFF	ON	AC synchro, pulsating current
DC	ON	ON	DC synchro, DC step

3. Setting of rotor voltage (measured between R1 and R2)

This step is for the AC synchro gyrocompass. For DC synchro see step 6.

Rotor Voltage	SW2-1	JP3
20 to 45 VAC	ON	#2
30 to 70 VAC	OFF	#2
40 to 90 VAC	ON	#1
60 to 135 VAC	OFF	#1

(continued on next page)

4. Setting of stator voltage (measured between S1 and S2)

Stator Voltage	SW2-2	SW2-3	JP2
20 to 45 VAC or 20 to 60 VDC	ON	OFF	#2
30 to 70 VAC or 40 to 100 VDC	OFF	OFF	#2
40 to 90 VAC	ON	OFF	#1
60 to 135 VAC	OFF	OFF	#1

5. Setting of gear ratio

Gear Ratio	SW1-1	SW1-2	SW1-3
x360	OFF	OFF	OFF
x180	ON	OFF	OFF
x90	OFF	ON	OFF
x36	ON	ON	OFF

6. Setting of power supply voltage

Voltage	JP4	JP5
20 to 45 VAC or 20 to 60 VDC	#2	#2
30 to 135 VAC or 40 to 100 VDC	#1	#1

7. Setting of data transmitting interval of NMEA0183

Set according to specifications of navigation aid connected.

Transmitting Interval	SW2-4
2 second	ON
1 second	OFF

8. Setting of data transmitting interval of AD-10S

Select data transmitting interval for each port by changing the proper jumper wire on JP6 or JP7.

NOTE: Use the interval 25ms for radar only.

Setting DIP switches and jumper wires by make and model of gyrocompass

The table below shows how to set the GC-7 for connection with various makes and models of gyrocompasses.

MANUFACTURER	MODEL	SPECIFICATIONS	SW1-1	SW1-2	SW1-3	SW1-4	SW1-5	SW1-6	SW1-7	SW1-8	SW2-1	SW2-2	SW2-3	JP1	JP2	JP3	JP4	JP5
FURUNO	GY-700	DC STEP-BY-STEP 100V 180x 5 WIRES OPEN COL- LECTOR COUPLING	ON	OFF	OFF	ON	OFF	OFF	ON	ON	-	OFF	OFF	#4, #5, #6	#2	-	#1	#1
ANSCHUTZ	STANDARD 2/3	AC SYNCHRO 50/60Hz ROTOR : 50/60V STATOR: 22V 360x	OFF	OFF	OFF	OFF	OFF	OFF	OFF	OFF	OFF	ON	OFF	#1, #2, #3	#2	#2	#1	#1
	STANDARD 4/6	AC SYNCHRO 50/60Hz ROTOR : 50/60V STATOR: 90V 360x	OFF	OFF	OFF	OFF	OFF	OFF	OFF	OFF	OFF	OFF	OFF	#1, #2, #3	#2	#1	#1	#1
YOKOKAWA NAVTEC [PLATH TYPE]	C-1/1A/2/3 A-55, B-55	AC SYNCHRO 50/60Hz ROTOR : 50/60V STATOR: 22V 360x	OFF	OFF	OFF	OFF	OFF	OFF	OFF	OFF	OFF	ON	OFF	#1, #2, #3	#2	#2	#1	#1
	CHZ-100/200 C-Jr, D-1Z/1/3, 1PS-2/3	AC SYNCHRO 50/60Hz ROTOR : 100V STATOR: 90V 360x	OFF	OFF	OFF	OFF	OFF	OFF	OFF	OFF	OFF	OFF	OFF	#1, #2, #3	#1	#1	#1	#1
PLATH	NAVIGAT II/III	AC SYNCHRO 50/60Hz ROTOR : 50/60V STATOR: 68V 360x	OFF	OFF	OFF	OFF	OFF	OFF	OFF	OFF	OFF	OFF	OFF	#1, #2, #3	#2	#2	#1	#1
TKIMEC [SPERRY TYPE]	ES-1/2/11 GLT-101/102/103/ 106K/107	AC SYNCHRO 50/60Hz ROTOR : 100/110V STATOR: 90V 36x	ON	ON	OFF	OFF	OFF	OFF	OFF	OFF	OFF	OFF	OFF	#1, #2, #3	#1	#1	#1	#1
	ES-11A TG-200 PR222R PR237L/H GM-21	AC SYNCHRO 50/60Hz ROTOR : 100/110V STATOR: 90V 90x	OFF	ON	OFF	OFF	OFF	OFF	OFF	OFF	OFF	OFF	OFF	#1, #2, #3	#1	#1	#1	#1
	MK-14 MCO-1/2/T MK-E4, MK-E1	DC STEP-BY-STEP 70V 180x COM(-), 3 WIRES(+)	ON	OFF	OFF	ON	OFF	OFF	ON	ON	-	OFF	OFF	#4, #5, #6	#2	-	#1	#1
	SR-130/140	DC STEP-BY-STEP 70V 180x 5 WIRES OPEN COL- LECTOR COUPLING	ON	OFF	OFF	ON	OFF	OFF	ON	ON	-	OFF	OFF	#4, #5, #6	#2	-	#1	#1
	TG-100-5000 PR-357/130/140 ES17 GLT-201/202/203	DC STEP-BY-STEP 70V 180x COM(+), 3 WIRES(-)	ON	OFF	OFF	ON	OFF	OFF	ON	ON	-	OFF	OFF	#4, #5, #6	#2	-	#1	#1
	SR-120, ES-16, MK-20	DC STEP-BY-STEP 35V 180x COM(+), 3 WIRES(-)	ON	OFF	OFF	ON	OFF	OFF	ON	ON	-	ON	OFF	#4, #5, #6	#2	-	#2	#2
ARMABRON	MK-10, MKL-1, SERIES 1351, MCO-4	DC STEP-BY-STEP 50V 180x COM(+), 3 WIRES(-)	ON	OFF	OFF	ON	OFF	OFF	ON	ON	-	OFF	OFF	#4, #5, #6	#2	-	#1	#1
ROBERTSON	SKR-80	DC STEP-BY-STEP 35V 180x COM(-), 3 WIRES(+)	ON	OFF	OFF	ON	OFF	OFF	ON	ON	-	ON	OFF	#4, #5, #6	#2	-	#2	#2

Function of DIP Switches and Jumper Wires

The function of each DIP switch and jumper wire is as listed below. Set them according to the specifications of the gyrocompass connected. After setting, reset CPU or turn the power off and then on again to write settings into the CPU.

DIP switch SW1

Segment	Function	Setting			
SW1-1, -2, -3	Gear ratio	SW1-1	SW1-2	SW1-3	
		OFF	OFF	OFF	x360
		ON	OFF	OFF	x180
		OFF	ON	OFF	x90
SW1-4, -5, -6	Type of gyrocompass	SW1-4	SW1-5	SW1-6	
		OFF	OFF	OFF	AC synchro
		OFF	OFF	OFF	DC synchro
		ON	OFF	OFF	DC step
SW1-7, -8	Frequency	SW1-7	SW1-8		
		OFF	OFF	50/60 Hz	
		ON	OFF	400 Hz	
		OFF	ON	500 Hz	
		ON	ON	DC	

DIP switch SW2

Segment	Function	Setting		
SW2-1	Rotor voltage	SW2-1		
		ON	20 to 45 VAC	
		OFF	30 to 70 VAC	
		ON	40 to 90 VAC	
SW2-2, -3	Stator voltage	SW2-2	SW2-3	
		ON	OFF	20 to 45 VAC
		OFF	OFF	30 to 70 VAC
		ON	OFF	40 to 90 VAC
SW2-4	NMEA0183 output interval	SW2-4		
		ON	2 second	
		OFF	1 second	
		OFF		
SW2-5	Self test	SW2-5		
		ON	self test on	
		OFF	self test off	
SW2-6, -7	Not used			
SW2-8	CPU reset	normally off; turn on and off to reset CPU.		

Jumper JP1

Segment	Function	Setting
#1, #2, #3	Type of gyrocompass	AC synchro
#2, #3, #4		DC synchro
#4, #5, #6		DC step

Jumper JP2

Segment	Function	Setting
#2	Stator voltage	20 to 70 VAC or 20 to 100 VDC
#1		40 to 135 VAC

Jumper JP3

Segment	Function	Setting
#2	Rotor voltage	20 to 70 VAC
#1		40 to 135 VAC

Jumper JP4

Segment	Function	Setting
#2	Supply voltage	20 to 45 VAC or 20 to 60 VDC
#1		30 to 135 VAC or 40 to 100 VDC

Jumper JP5

Segment	Function	Setting
#2	Supply voltage	20 to 45 VAC or 20 to 60 VDC
#1		30 to 135 VAC or 40 to 100 VDC

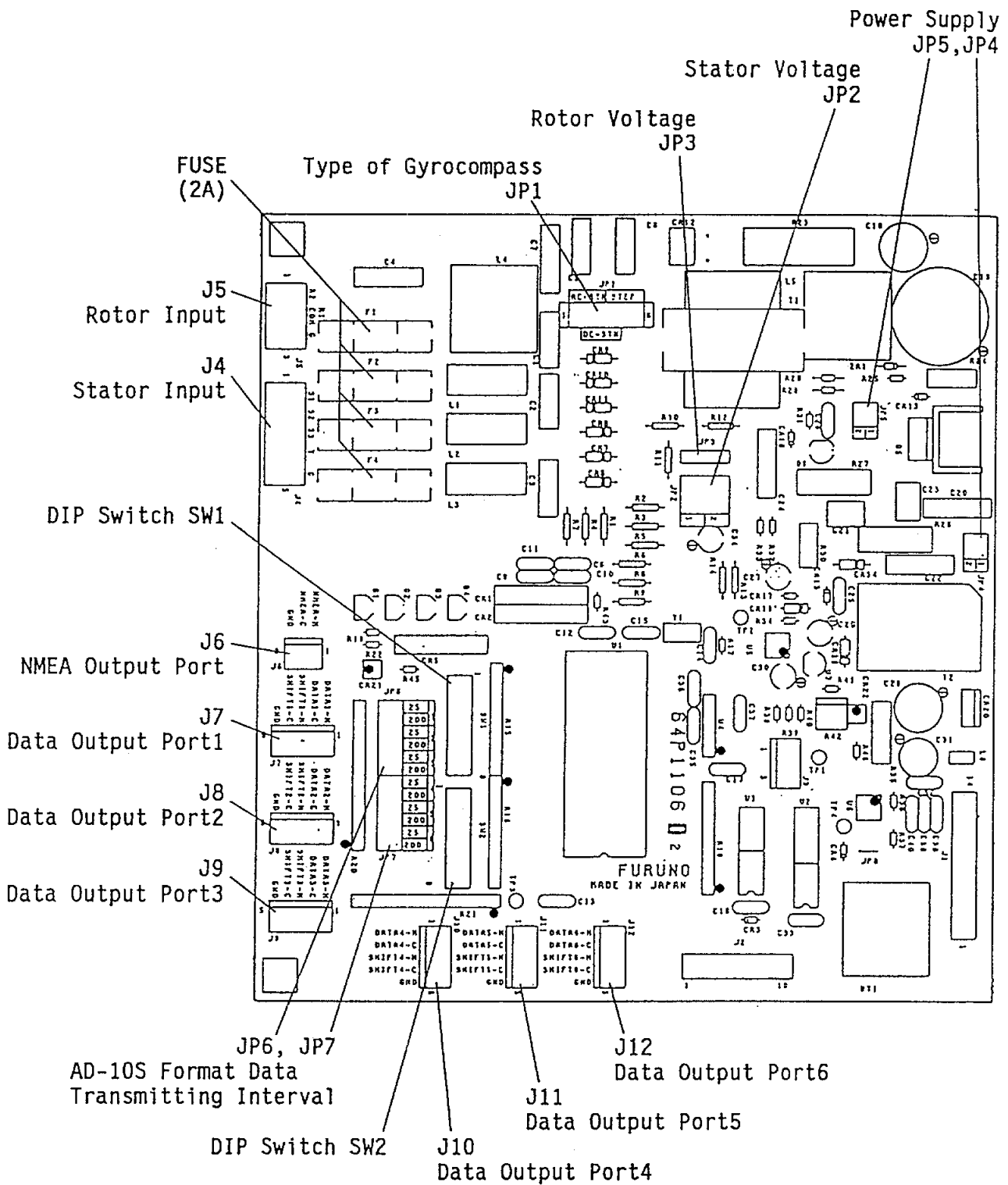

Figure A-2 GYRO PROCESSOR Board

Setting of Heading

1. After making sure the gyrocompass is working, transmit the radar. (You should see the indication "HDG" at the top of the radar screen.)
2. Open panel 3.
3. Press the HOLD switch to disengage the computing circuit from the gyrocompass. (LED CR1 lights.)
4. Press the UP (or DOWN) switch to duplicate the gyrocompass reading at the top of the screen. (Each press of these keys changes the readout by 0.1°. Press and hold down a key for more than seconds to change the readout by 1°.)
5. Press the HOLD switch. (LED CR1 extinguishes.)

NOTE: In some cases, the gyrocompass rotation may be the opposite of the displayed bearing in spite of correct connections. In this case try exchanging two connections among S1, S2 and S3 between the GYRO SWITCH Board and the GYRO PROCESSOR Board.

Local Assembling of GC-7 Gyro Converter

GC-7 Complete Set

No.	Name	Type	Code No.	Q'ty	Remarks
1	Gyro Processor Board	[A]64P1106	004-412-220	1	
2	Gyro Switch Board	CG-4137	008-167-350	1	
3	Protective Cover	03-010-1414	100-002-580	1	for CG-4137 board
4	Instruction Label	64-014-2021	100-132-701	1	
5	Washer-head Screw A	M2.6x5	000-800-973	2	
6	Washer-head Screw B	M3x8	000-881-404	9	
7	VH Connector Assy.	03-1521	008-418-530	1	P104/P105 - P1605
8	Crimp-on Lug	FV1.25-M3	000-538-110	5	Installation Materials CP03-11400
9	Fuse	FGMB 2A	000-122-000	4	Spare Parts SP03-09000

Fixing of P.C. Boards and Connections

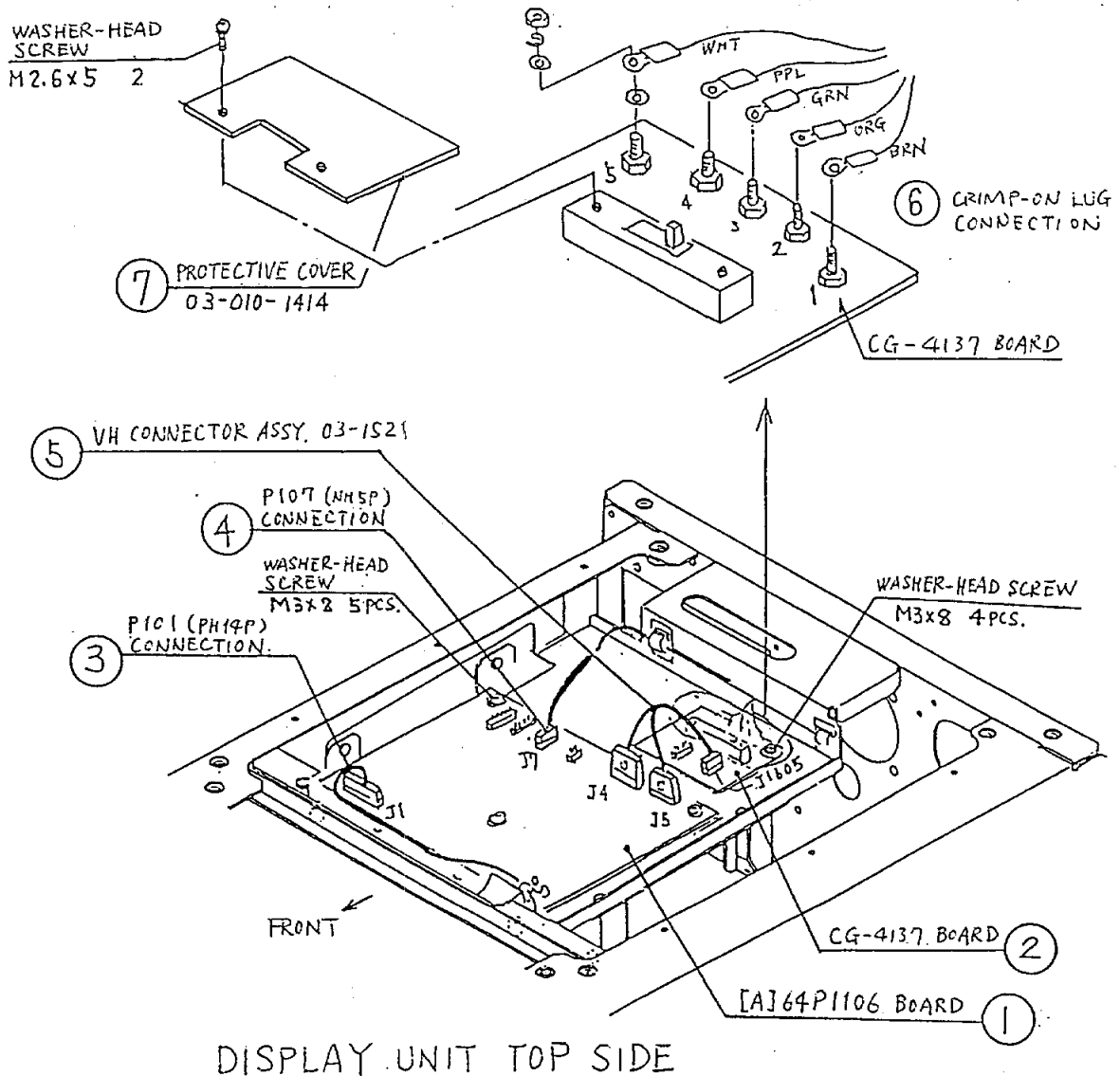

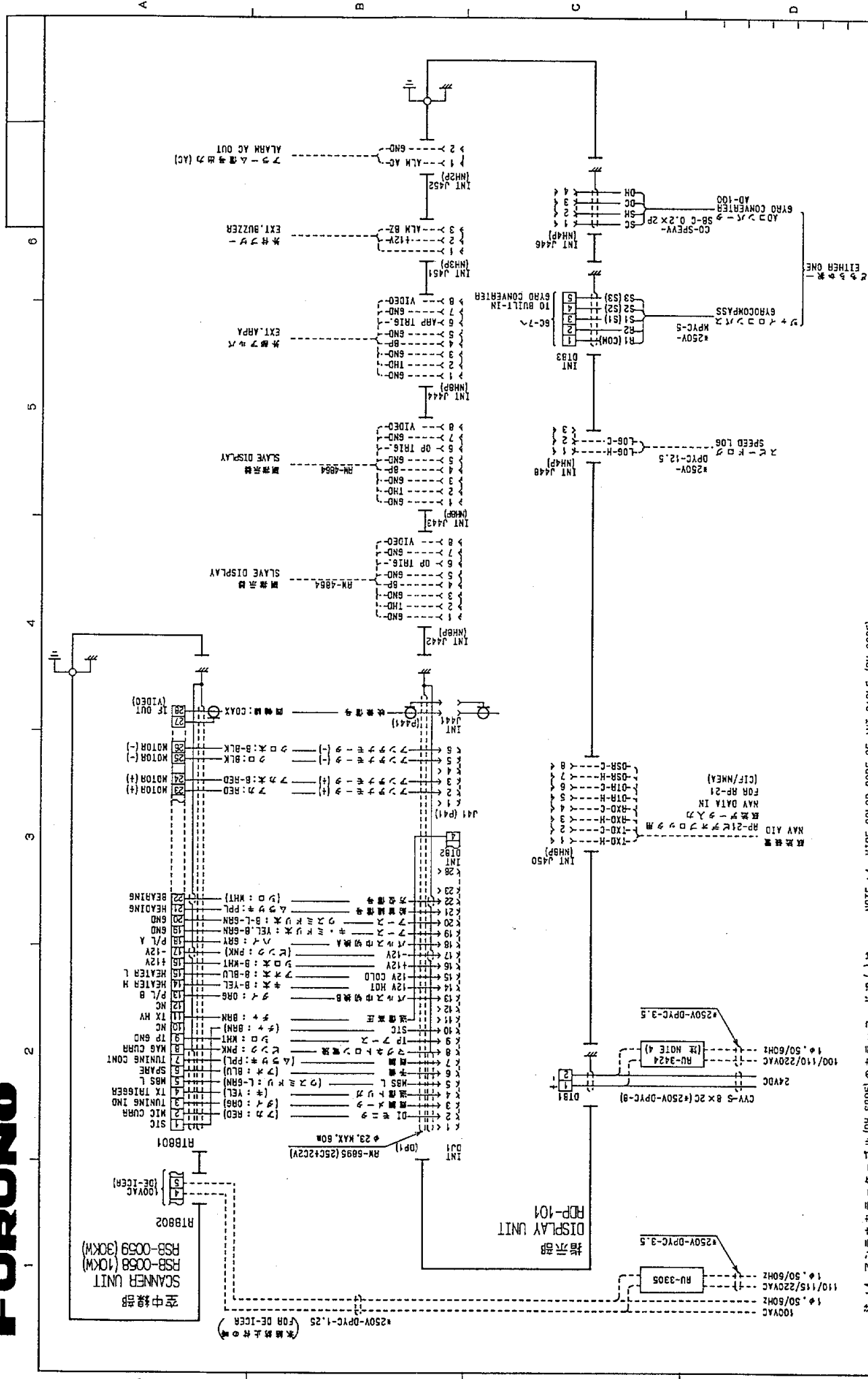

注: 1. アンテナカラーコード (RK-6895) のカラーコードで () は内側シールド内の線を示す。
 2. シールドは両端で完全にアースすること。
 3. *印は造船所支給 (現地手配)。
 4. FR-14100Sで250cm型空中線 (SN4A) の場合は、雙流器としてRU-1746Bも使用可。

NOTE: 1. WIRE COLOR CODE OF ANT CABLE (RK-6895) () : INSIDE WIRE, B: LARGE WIRE, L: LIGHT COLOR
 2. SHIELD SHOULD BE EFFECTIVELY GROUNDED AT BOTH ENDS.
 3. *MARK: SHIPYARD SUPPLY (PREPARED LOCALLY)
 4. FOR FR-14100S USING 250cm TYPE ANTENNA (SN4A), RECTIFIER UNIT RU-1746B MAY SUBSTITUTE FOR RU-3424.

承認 APPROVED	承認者 T. MAKANO	名称 FR-14100S/14300S
検閲 CHECKED	検閲者 N. SAITO	タイトル 相互結線図
製図 DRAWN	製図者 I. ANANO	図番 C3369-C01-B

INTERCONNECTION DIAGRAM

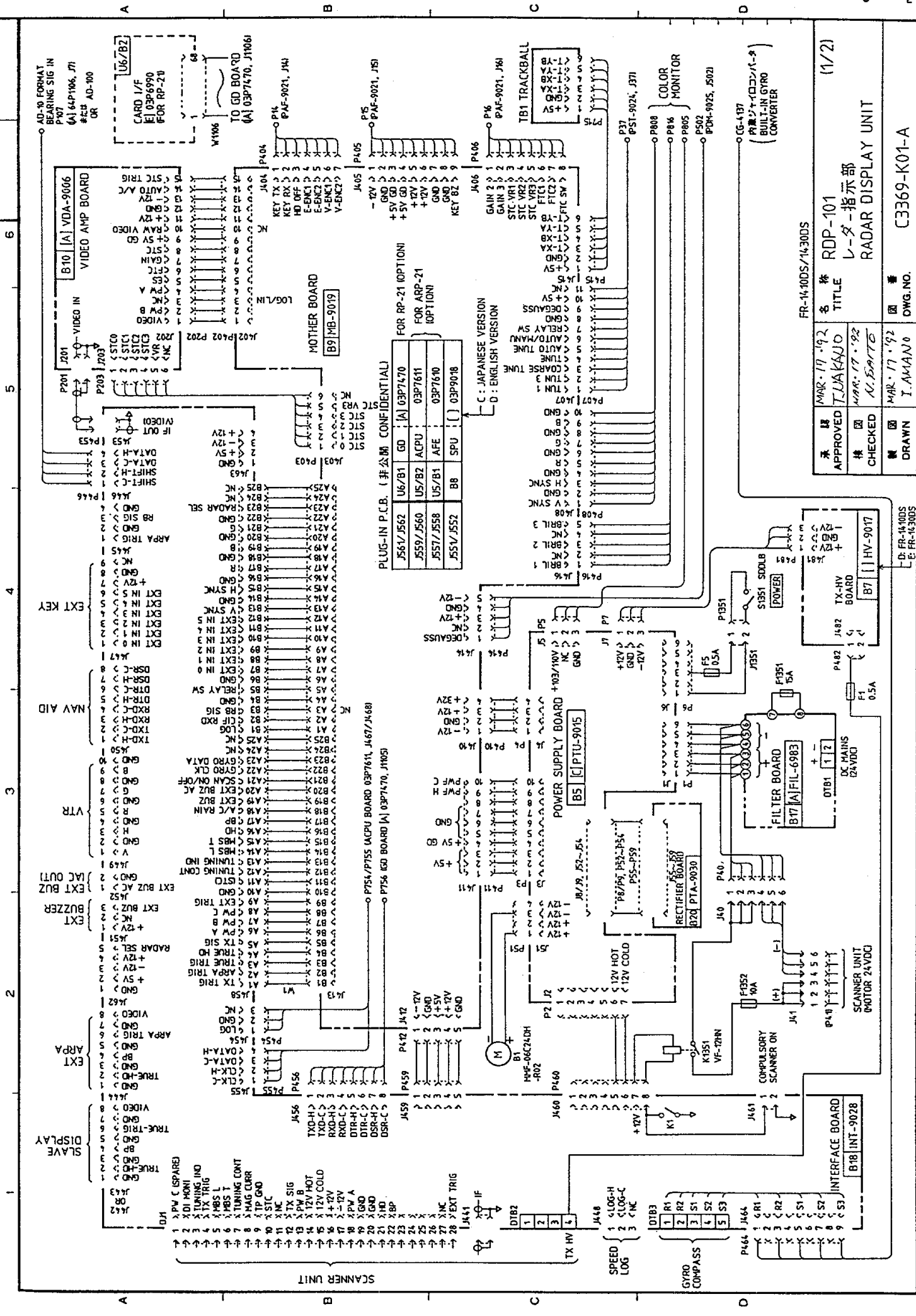

PLUG-IN P.C.B. (非公開 CONFIDENTIAL)

J561/J562	U6/B1	GD	A	03P7470
J559/J560	U5/B2	ACPU		03P7611
J557/J558	U5/B1	AFE		03P7610
J551/J552	B8	SPU		03P9018

FOR RP-21 OPTION
FOR ARP-21 OPTION

FR-14-100S/14-300S

承認	MARK-17-192	名称	RDP-101
批准	IZUAKAO	标题	レーダ指示部
検査	MARK-17-92		RADAR DISPLAY UNIT
検査	K. Igarashi		
製図	MARK-17-92	製図者	
製図	I. Amano	製図者	

(1/2)

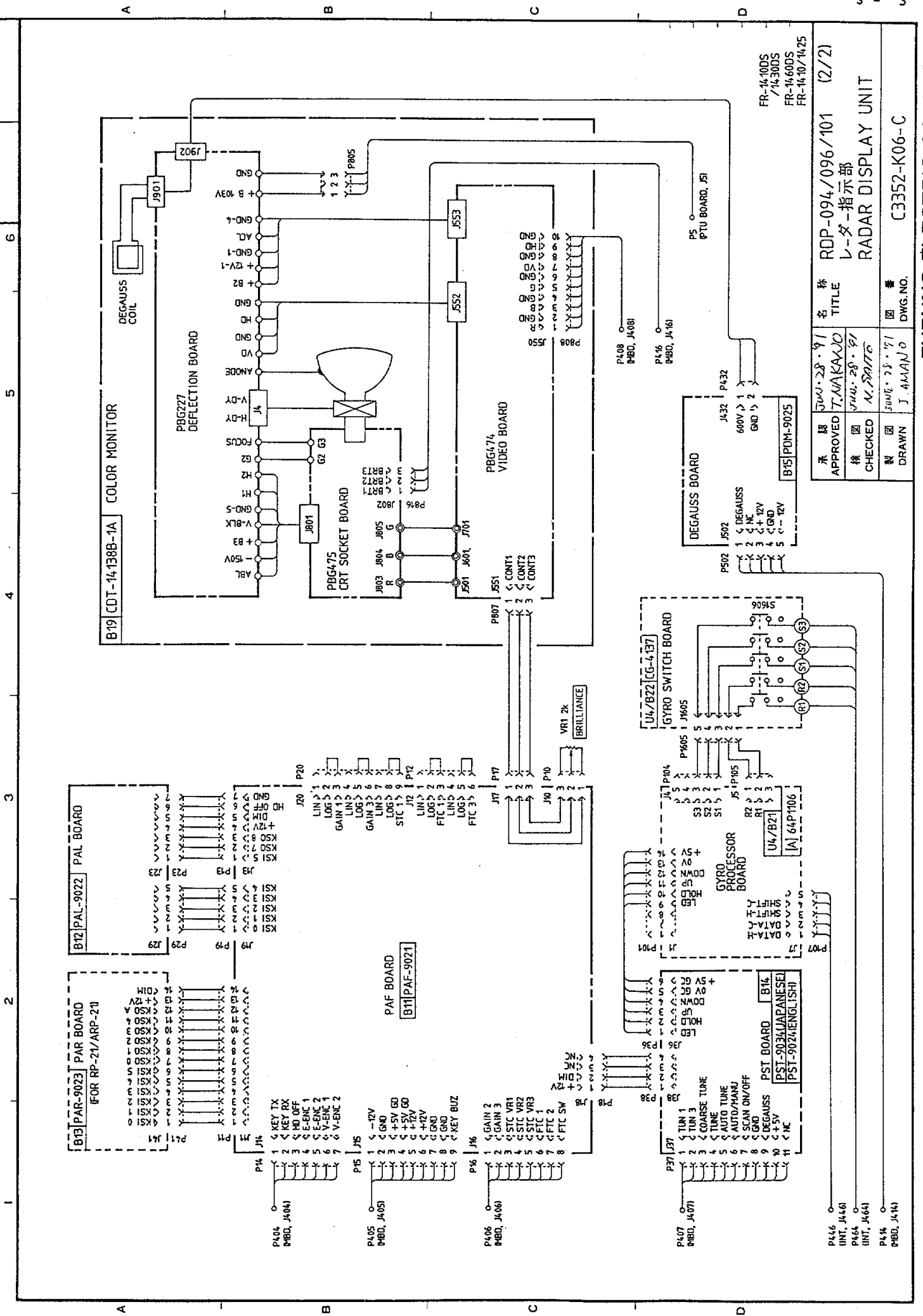

承認 APPROVED	検査 CHECKED	製図 DRAWN	名称 TITLE
3000.28.91 T. AKAKAWA	3000.28.91 M. SAITO	3000.28.91 J. AMANO	RDP-094/096/101 (2/2) レ-タ-指示部 RADAR DISPLAY UNIT
			図番 DWG. NO. C3352-K06-C

FR-14100S
FR-14300S
FR-14600S
FR-1410/1425

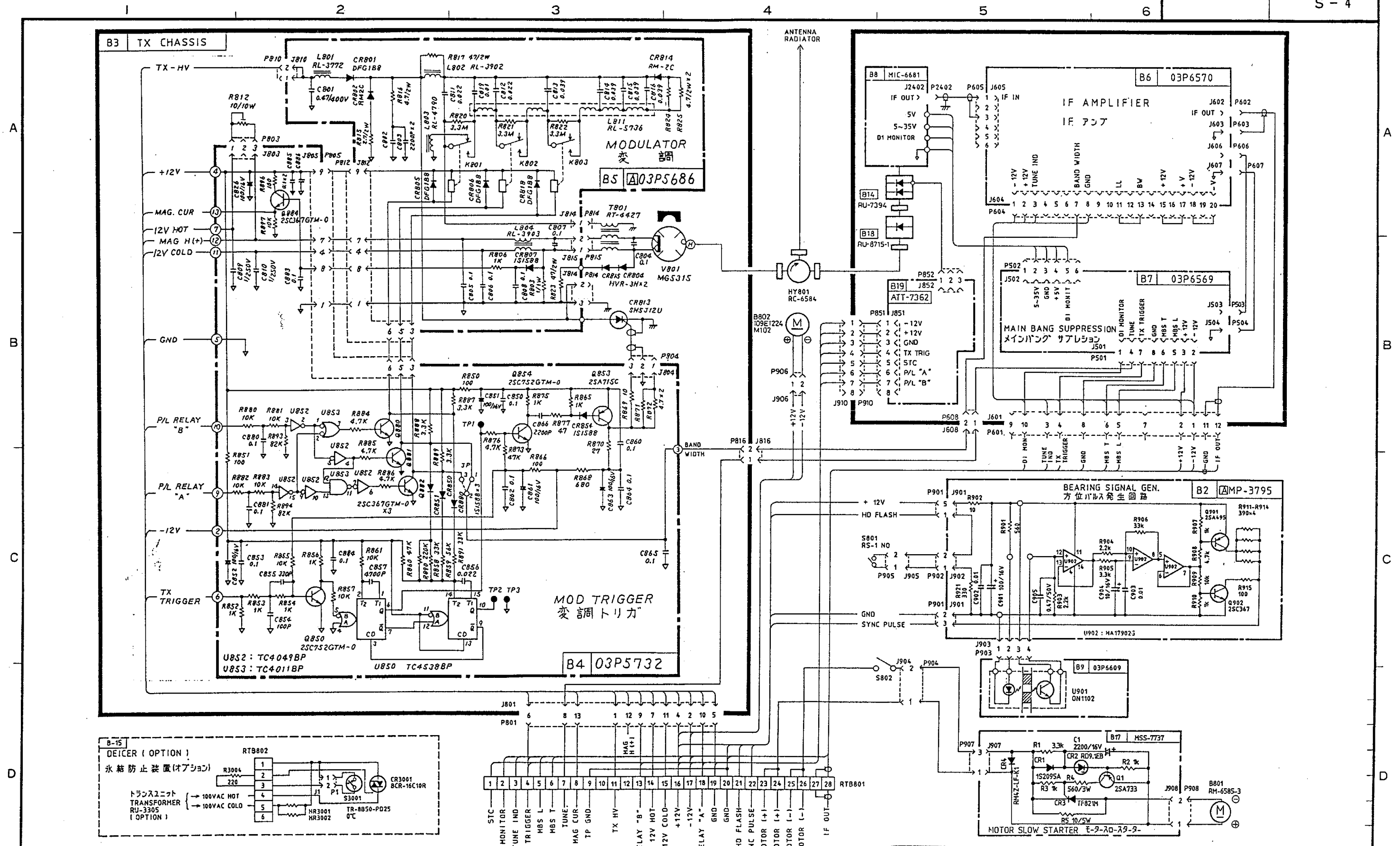

NOTE: 特記なき抵抗の単位は Ω, 1/4W またコンデンサは μF.
 ALL RESISTANCE IN OHMS, 1/4W AND CAPACITANCE IN MICROFARADS UNLESS NOTED OTHERWISE.

FR-1410DS

承認 APPROVED	MAR. 16. '92 T. NAKAWO	名称 TITLE	RSB-0058 空中線部総合回路図 SCANNER UNIT
検 CHECKED	MAR. 16. '92 N. SAITO	図番 DWG. NO.	C3369-K02-A
製 DRAWN	MAR. 16. '92 I. AMANO		

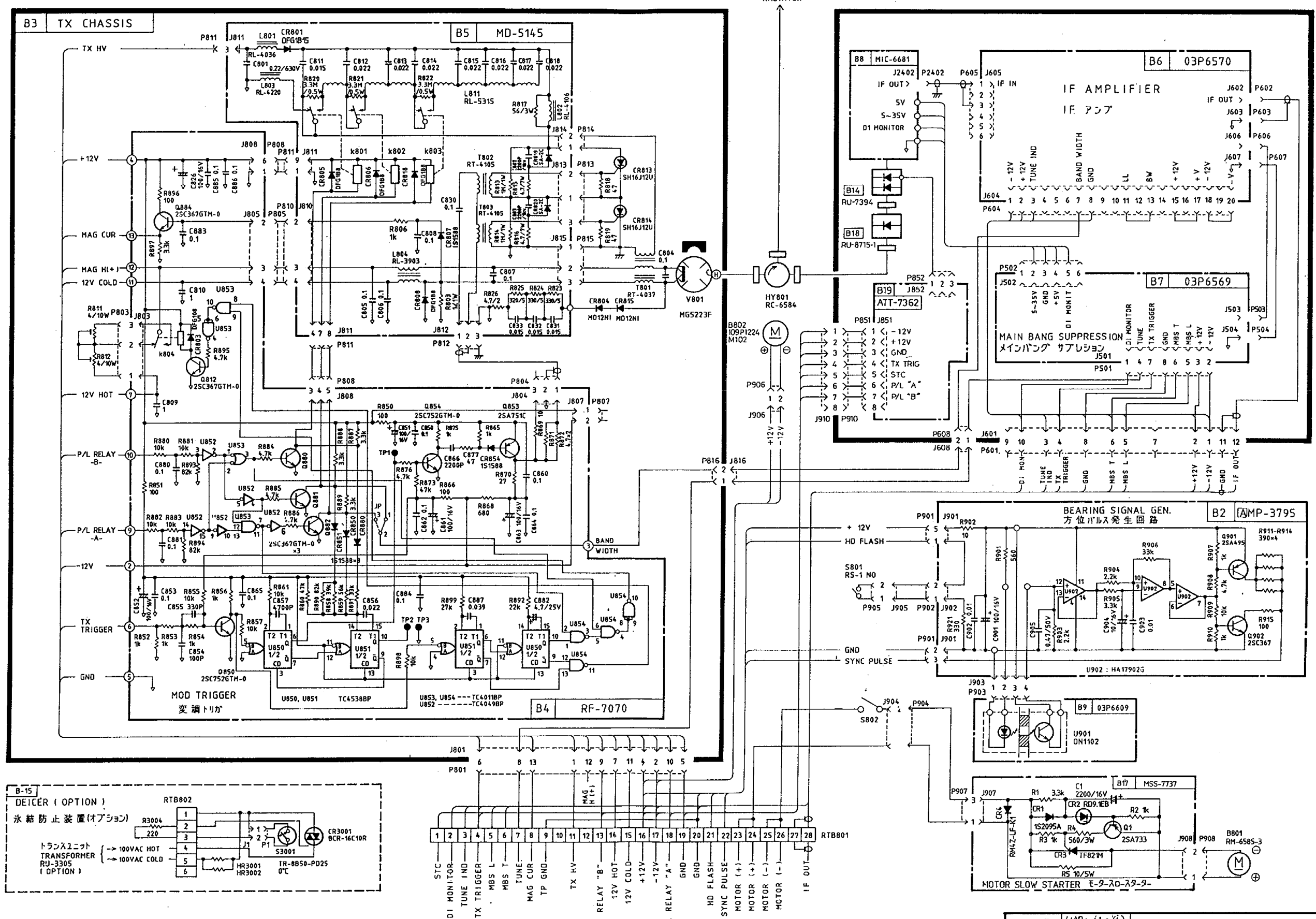

NOTE: 特記なき抵抗の単位は Ω, 1/4W またコンデンサは μF.
 ALL RESISTANCE IN OHMS, 1/4W AND CAPACITANCE IN MICROFARADS UNLESS NOTED OTHERWISE.

承認 APPROVED	1'AR-11'92 TAKANO	名称 TITLE	空中線部総合回路図
検閲 CHECKED	Mar. 11 '92 M. SARTO	RSB-0059	SCANNER UNIT
製図 DRAWN	MAR 11 '92 I. AMANO	図番 DWG. NO.	C3370-K01-B

FR-1430DS

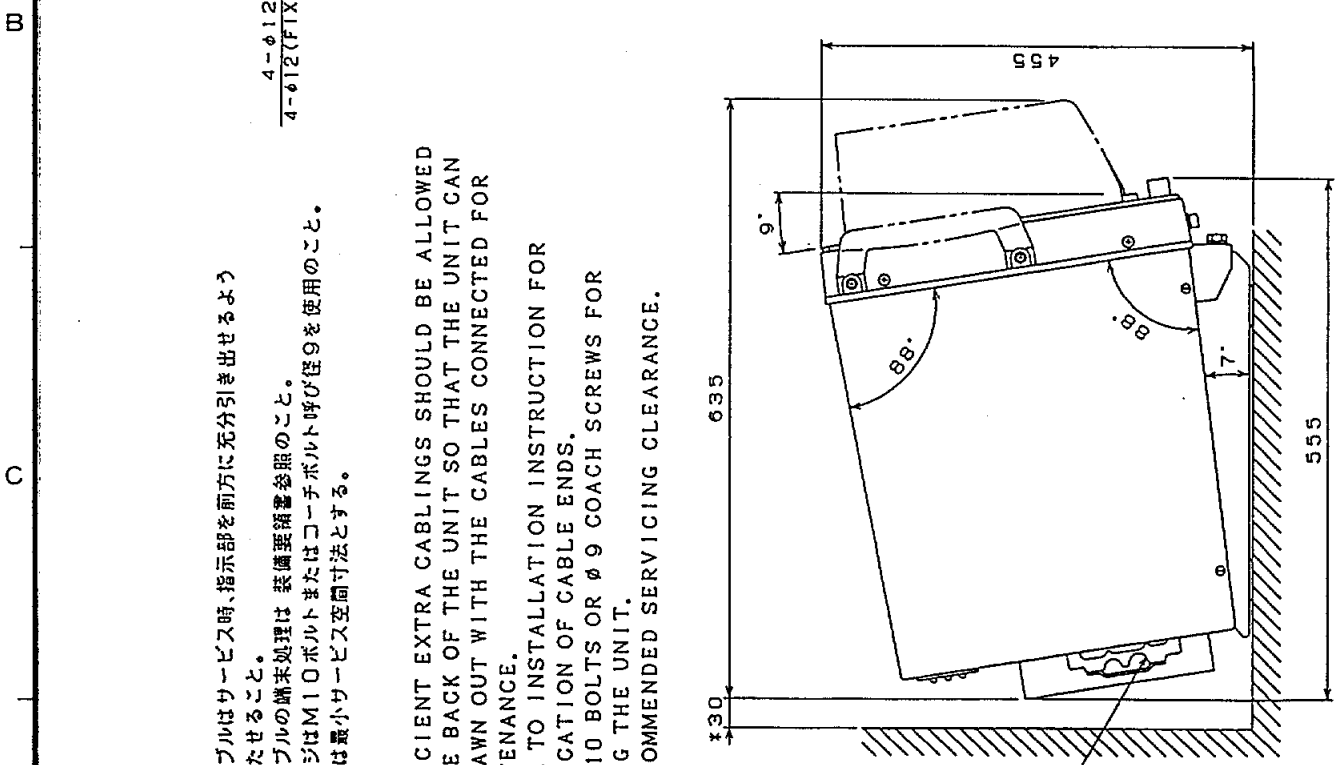
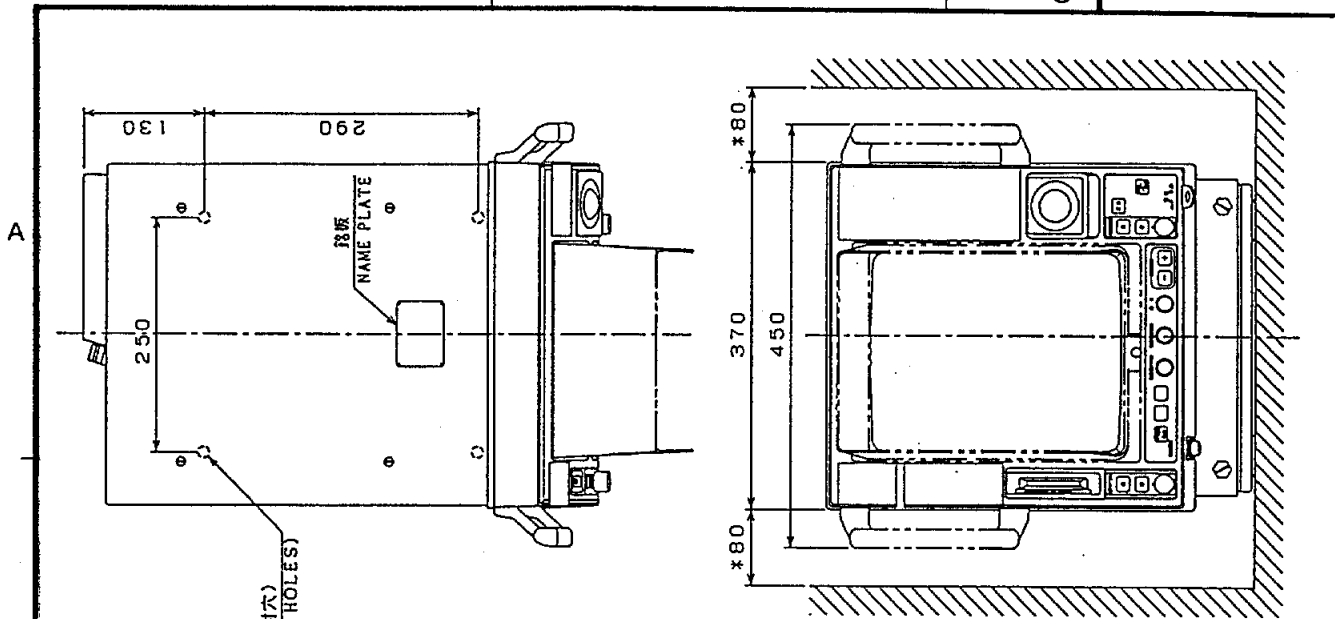

注 記

- 1) 装置ケーブルはサービス時、指示部を前方に充分引き出せるよう余裕を持たせること。
- 2) 装置ケーブルの端末処理は 装置要領書参照のこと。
- 3) 取付用ネジはM10 ボルトまたはコーチボルト呼び径9を使用のこと。
- 4) *印寸法は最小サービス空間寸法とする。

NOTE

- 1) SUFFICIENT EXTRA CABLING SHOULD BE ALLOWED AT THE BACK OF THE UNIT SO THAT THE UNIT CAN BE DRAWN OUT WITH THE CABLES CONNECTED FOR MAINTENANCE.
- 2) REFER TO INSTALLATION INSTRUCTION FOR FABRICATION OF CABLE ENDS.
- 3) USE M10 BOLTS OR $\phi 9$ COACH SCREWS FOR FIXING THE UNIT.
- 4) *: RECOMMENDED SERVICING CLEARANCE.

FCR-1400 MARK-3 SERIES
FR-1400 SERIES

品番 ITEM	品名 NAME	材質 MATERIAL	数量 Q'TY	図番 DWG.NO.	摘要 REMARKS
承認 APPROVED	MAR.23.'91 T. NAKAJO	三角法 THIRD ANGLE PROJECTION		名称 TITLE	RDP-094/096/097 14" レーダー指示部外寸図 RADAR DISPLAY UNIT
検図 CHECKED	MAR.23.'91 N. SAITO	尺 SCALE	1/8	図番 DWG.NO.	
製図 DRAWN	MAR.23.'91 I. AMANO	重量 WEIGHT	33 kg	図番 DWG.NO.	C3352-G01-C

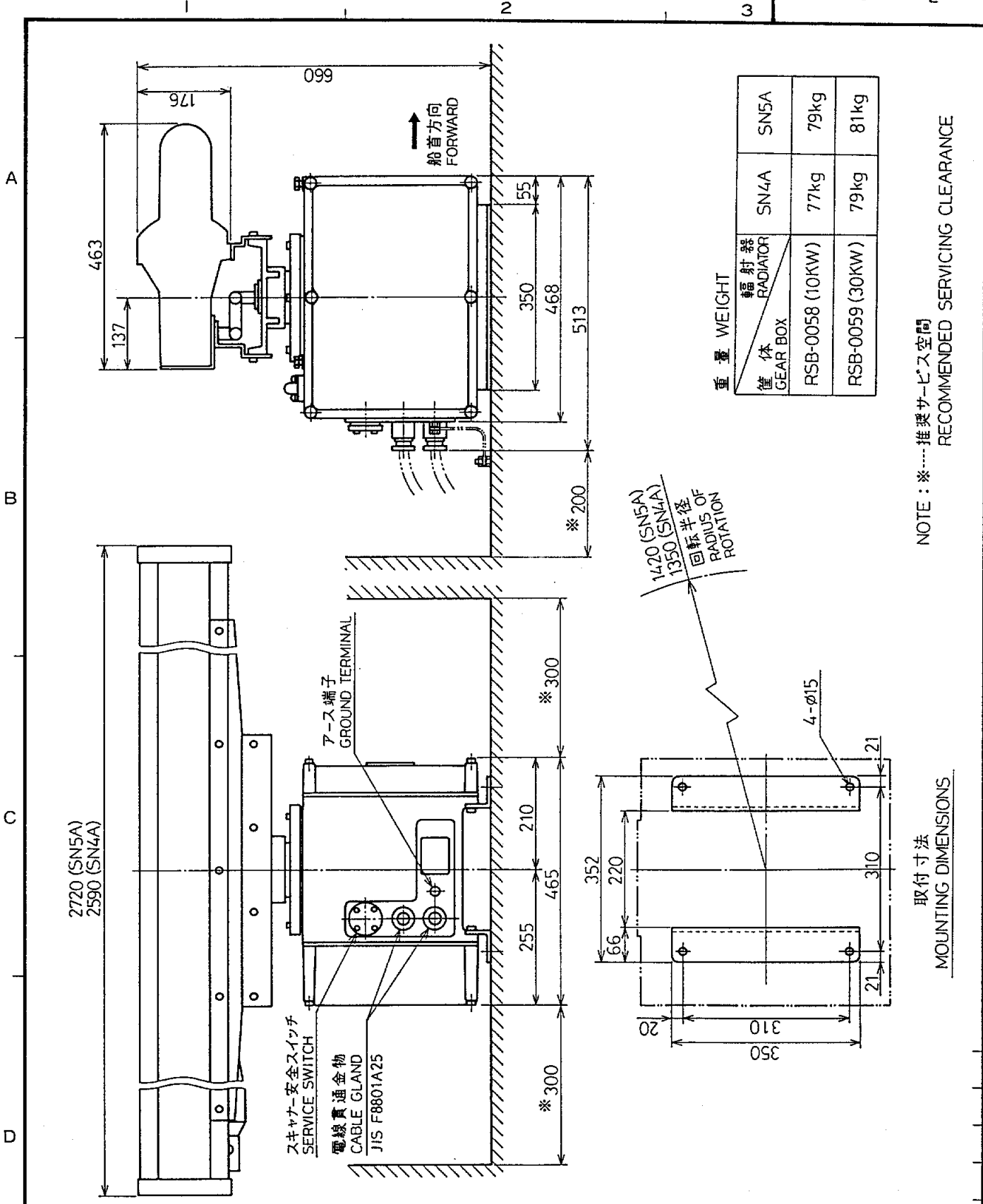

重量 WEIGHT	輻射器 RADIATOR	機体 GEAR BOX
SN5A	SN4A	RSB-0058 (10KW)
79kg	77kg	RSB-0059 (30KW)
81kg	79kg	

NOTE: *...推奨サービス空間
RECOMMENDED SERVICING CLEARANCE

取付寸法
MOUNTING DIMENSIONS

FR-1410DS/1430DS

品番 ITEM	品名 NAME	材質 MATERIAL	数量 Q'TY	図番 DWG.NO.	摘要 REMARKS
承認 APPROVED MAR. 11. 92 T. YAKANO	三角法 THIRD ANGLE PROJECTION	名称 TITLE	SN4A/5A-RSB-0058/0059 レーダ-空中線部外寸図 RADAR SCANNER UNIT		
検図 CHECKED MAR. 11. 92 N. SAITO	尺度 SCALE	1/10			
製図 DRAWN MAR. 11. 92 I. AMANO	重量 WEIGHT	kg	図番 DWG. NO.	C3369-G01-A	

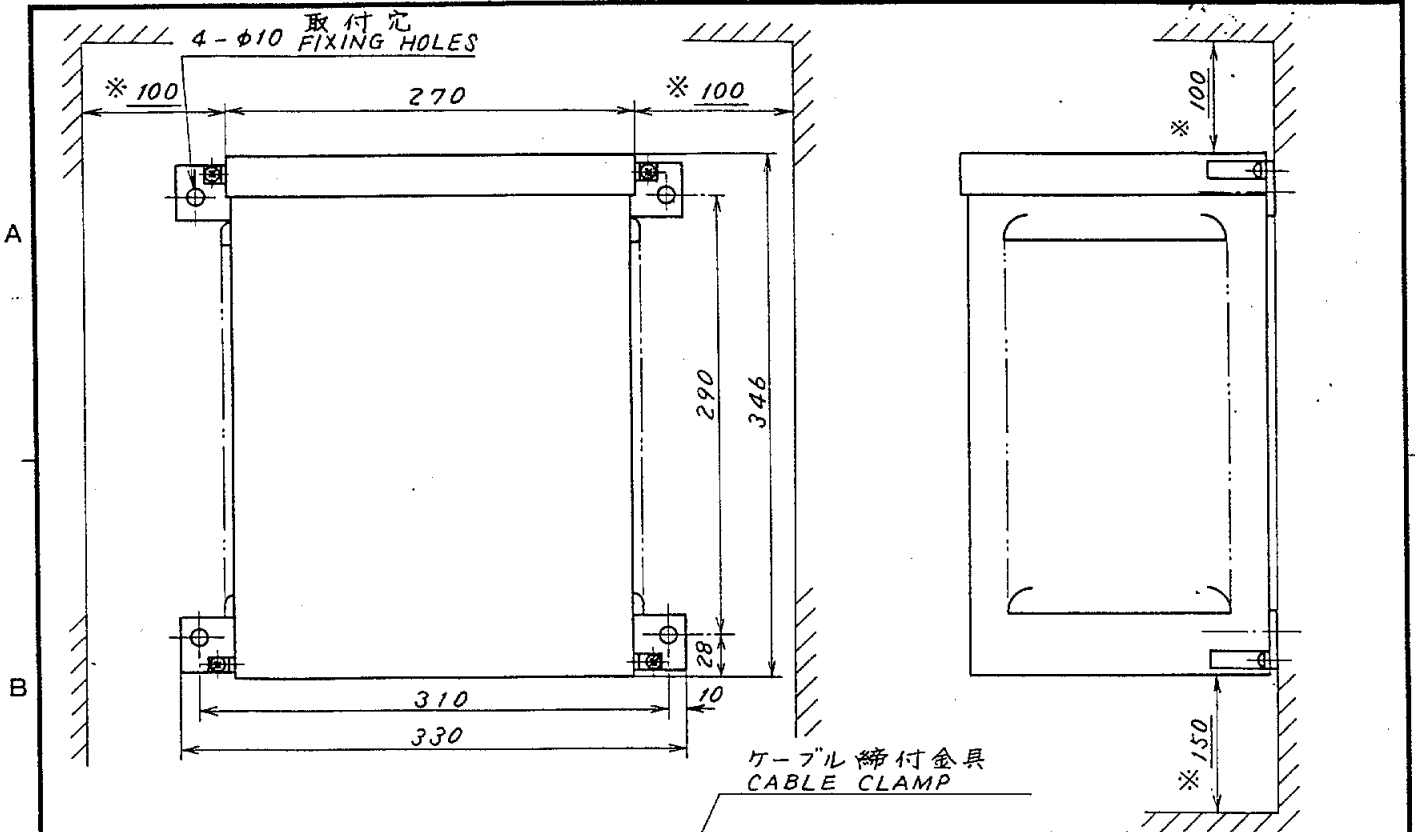

※: 最小サービス空間
MIN. SERVICING CLEARANCE

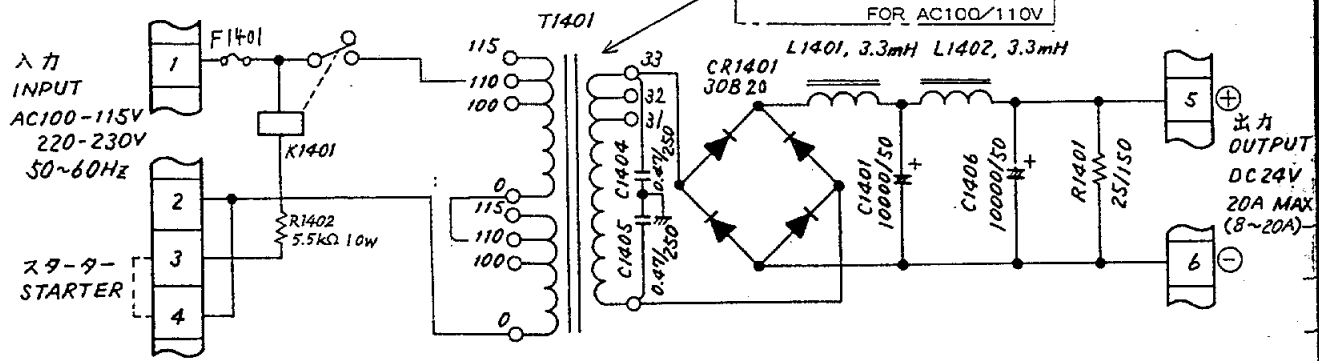
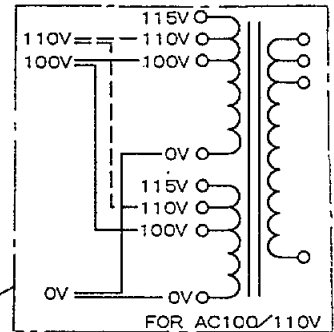
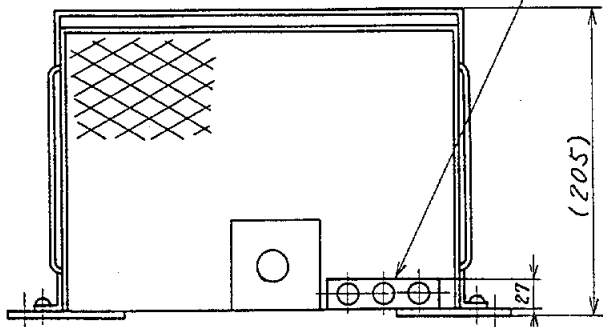

注記 AC100V 入力に対しては T1401 の一次巻線の接続を変更し、リレー抵抗 R1402 の両端をジャンパーで短絡する。
NOTE: FOR 100VAC INPUT, CHANGE T1401 PRIMARY WINDINGS CONNECTIONS AND PUT JUMPER ACROSS R1402.

DRAWN APR 11 '97 T. YAMASAKI		TYPE RU-3424	
CHECKED APR. 17 '97 K. Kusuruki		名称 整流器	
APPROVED		外寸図	
SCALE 1/5	MASS 25 kg	APPLICABLE TO; (MODEL)	BLOCK NO. NAME RECTIFIER UNIT
DWG NO. C3002-004-H		OUTLINE DRAWING	

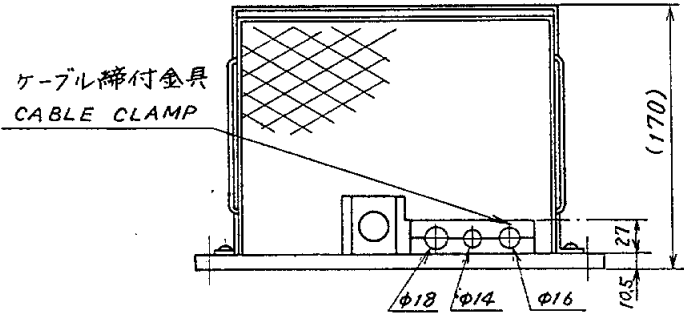
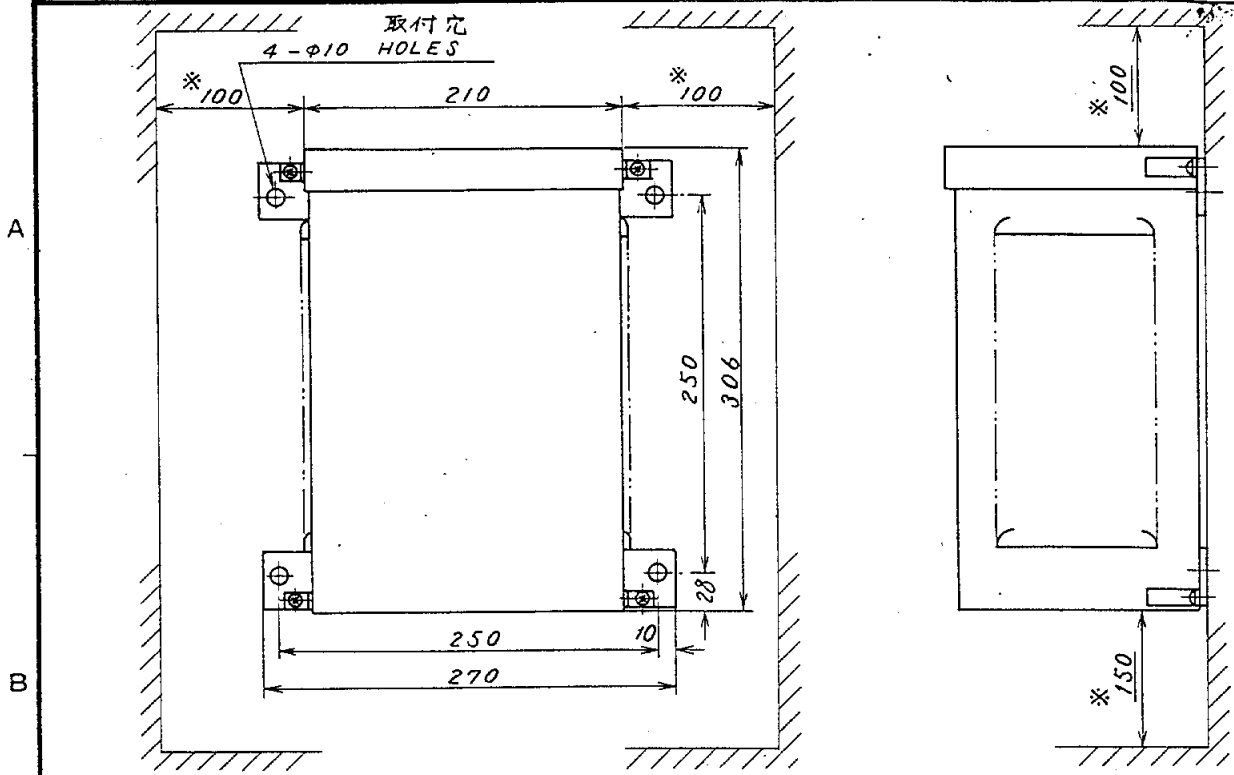

NOTE 1. ※: 推奨サービス空間
RECOMMENDED SERVICING CLEARANCE.

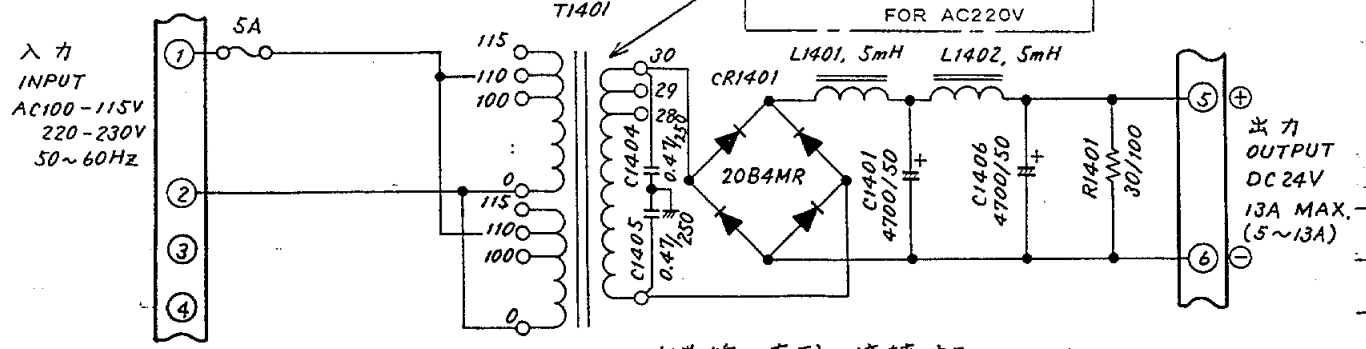
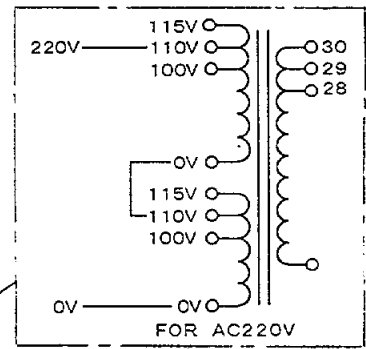

注 AC220V 入力に対しては T1401 の一次巻線を直列に接続する。

NOTE FOR 220VAC INPUT, CONNECT T1401 PRIMARY WINDINGS IN SERIES.

DRAWN Apr 11 '97 TYAMASAKI				TYPE RU-1746B-2
CHECKED Apr 15 '97 K. Kusunoki				名称 整流器
APPROVED				外寸図
SCALE 1/5	MASS 17 kg	APPLICABLE TO; (MODEL)	BLOCK NO.	NAME RECTIFIER UNIT
DWG NO. C3002-002-M				OUTLINE DRAWING

A

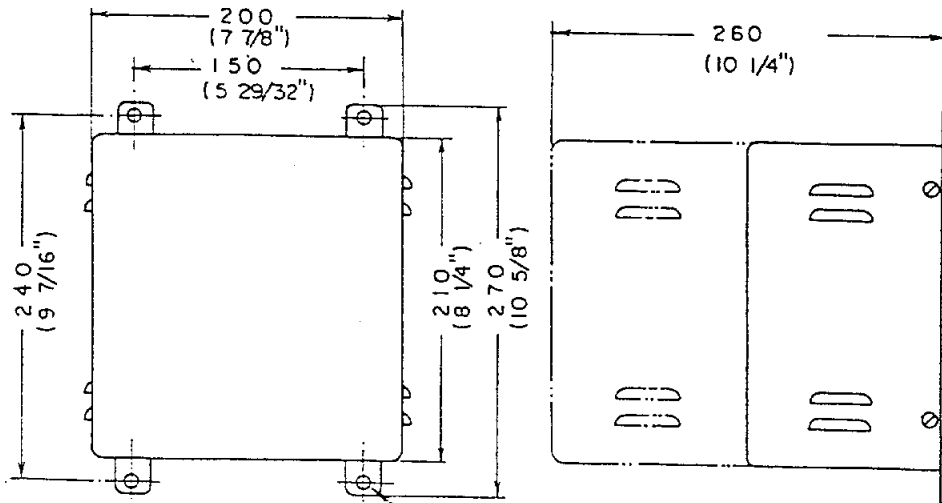

取付穴
4-7 ϕ (17/64") FIXING HOLE

B

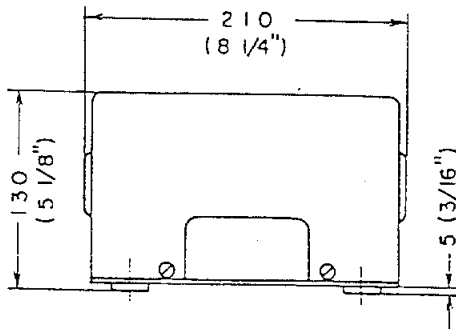

重量 WEIGHT: 12 kg (27 lbs)
単位 UNIT: mm (inches)

C

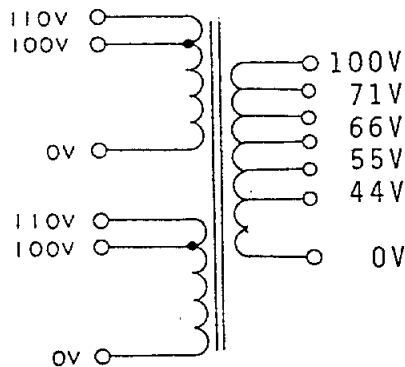

D

コンパス安全距離 COMPAS SAFE DISTANCE

スタンダード STANDARD	2.1 M
ステアリング STEERING	1.5 M

氷結防止 DE-ICER

承認 APPROVED	品番 ITEM	品名 NAME	材質 MATERIAL	数量 Q'TY	図番 DWG.NO.	摘要 REMARKS
		三角法 THIRD ANGLE PROJECTION				名称 TITLE TRANS ユニット
検査 CHECKED	AUG. 19. 83	尺度 SCALE	/			RU-3305 TRANSFORMER UNIT
製図 DRAWN	19. Aug. '83 H.K.	重量 WEIGHT	12.2 kg		図番 DWG.NO. C3003-004-C	

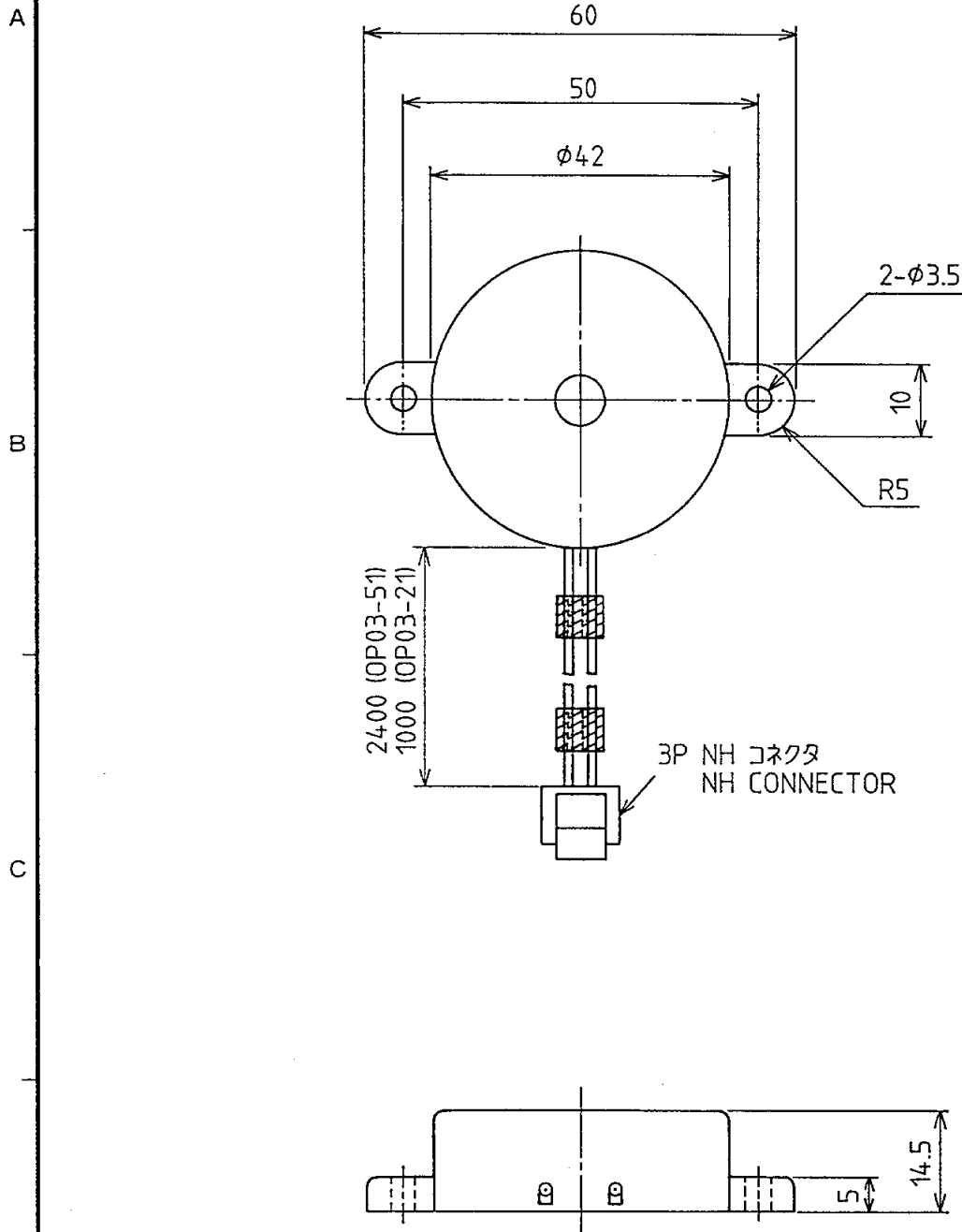

品番 ITEM	品名 NAME	材質 MATERIAL	数量 Q'TY	図番 DWG.NO.	摘要 REMARKS
承認 APPROVED	FEB.15.'89 T. UAKAYU	三角法 THIRD ANGLE PROJECTION	名称 TITLE	OP03-21 外付ブザー OP03-51 EXTERNAL BUZZER	
検図 CHECKED	Feb.15.'89 N. SAITO	尺度 SCALE	1/1		
製図 DRAWN	Feb.15.'89 I. AMANO	重量 WEIGHT	kg	図番 DWG.NO.	C5094-008-B

FURUNO

REVISION RECORD OF OPERATOR'S/INSTALLATION MANUAL

MODEL: FR140DP / 1430DP PUBLICATION NO.: IM-E3369-0

REV. NO.	DATE	REVISED PAGE	DETAILS	PERSON IN CHG.
A	'92.5	—	First Edition	
B	'97.4	i, ii	PL記述追加	三好
		iv, v	A-シ番号の変更	
		0-1	115V → 220VAC	
		0-4	C3369-M01-A → B	
		0-5	C3369-M02-A → B	
		2-5	320882 → FWD1.25-3	
		3-14	MAIN → MAN	
		3-18	03590301 → 03590321 ; 03590311 → 03590331	
		2-10	VIDEO AMPLIFIER LEVEL a BTR	

①
②
③
④
⑤
⑥
⑦
⑧